



STATENS GEOTEKNISKA INSTITUT
BIBLIOTEKET

STATENS GEOTEKNISKA INSTITUT

SWEDISH GEOTECHNICAL INSTITUTE

No. **4**

SÄRTRYCK OCH PRELIMINÄRA RAPPORTER

REPRINTS AND PRELIMINARY REPORTS

Supplement to the "Proceedings" and "Meddelanden" of the Institute

Contributions to the Fifth International Conference
on Soil Mechanics and Foundation Engineering,
Paris 1961.

Part II.

Suggested Improvements in the Liquid Limit Test, with Reference to
Flow Properties of Remoulded Clays

by R. Karlsson

Reprinted from the Proceedings of the Fifth International Conference on
Soil Mechanics and Foundation Engineering, Paris 1961.

STOCKHOLM 1961

Preface

The Swedish Geotechnical Institute here presents a report from the "Proceedings of the 5th International Conference on Soil Mechanics and Foundation Engineering", 1961, containing a laboratory study on methods of determining the liquid limit for various remoulded soils, and some flow properties. The Swedish fall-cone method is utilized in the study.

Attention is drawn to the fact that the characteristics of the Casagrande's flow curve and the parallel characteristics of the fineness number method presented have occasionally been given the same symbols. It should also be noted that the further investigation with a 45-degree cone mentioned in the paper showed that also for this cone the k-value was dependent upon the soil proper.

A limited number of copies of this reprint is being issued as exchange matter and for distribution to laboratories and others on our mailing list who did not attend the above conference.

Stockholm, October, 1961

SWEDISH GEOTECHNICAL INSTITUTE

Suggested Improvements in the Liquid Limit Test, with Reference to Flow Properties of Remoulded Clays

Possibilités d'améliorer l'essai de la limite de liquidité, et détermination de quelques propriétés d'écoulement d'argiles remaniées

by R. KARLSSON, Swedish Geotechnical Institute

Summary

When classifying plastic soils the "fineness number" is used in many Scandinavian geotechnical laboratories instead of the Atterberg liquid limit determined in accordance with Casagrande's method. The fineness number is defined as the water content at a certain relative strength of remoulded material, determined by the fall-cone test method.

The fineness number and the liquid limit, the first-mentioned method being more objective, have been compared for a large number of samples. The results are correlated and correspond fairly well. For silt the fineness number is, however, greater than the liquid limit. For clays with a sensitivity greater than 10, organic soils and bentonite, the fineness number is less than the liquid limit.

When determining the fineness number, the variation of the shear strength with the water content has been established with remoulded soils in both plastic and liquid state. A "one-point method" for determining the fineness number has also been suggested.

The fall-cone test has been compared to the laboratory vane test for some typical soils. It has been shown that when calibrating the cone test both cone apex and type of soil influence the results, for a certain apex probably rather independent of the soil. Stress-strain curves have been plotted as well as shearing resistance-angular velocity curves. These curves give an indication of how the strength is influenced by thixotropic and structural viscosity effects.

Introduction

A common method of classifying plastic soils is the determination of the Atterberg consistency limits (1911, 1913, 1914, 1916), in the first place the liquid limit and the plastic limit. By the first-mentioned limit is meant the lowest (theoretically) moisture content, in percentage of dry weight, of the liquid state, defined by Atterberg as "the percussion liquid limit". By the latter is meant the lowest (theoretically) moisture content of the plastic state defined by ATTERBERG as "the outroll limit".

In addition, the fall-cone method of determining consistency, developed by the Geotechnical Commission of the Swedish State Railways 1914-1922 (1922), the chairman of which was W. Fellenius and secretary J. Olsson, is used in Sweden.

The fall-cone method* (referred to below as the cone method) implies that a metal cone of a certain weight and with a certain apex angle is suspended over a horizontally levelled sample of soil, with the point barely touching the surface. The cone is allowed to drop into the sample, and the depth of the impression gives a measure of the cohesion of the soil.

* The fall-cone test is described in detail in the Final Report of the Geotechnical Commission and by Caldenius & Lundström (1956).

Sommaire

Pour classer les sols plastiques le « nombre de finesse » (« finlekstalet ») s'emploie dans beaucoup de laboratoires géotechniques scandinaves au lieu de la limite de liquidité d'Atterberg déterminée conformément à la méthode de Casagrande. Le nombre de finesse se définit comme la teneur en eau à une certaine résistance relative de matière remaniée, déterminée au moyen de la méthode d'essai au cône.

Le nombre de finesse et la limite de liquidité (la première méthode étant plus objective) ont été déterminés pour ce grand nombre d'échantillons. Les résultats respectifs correspondent assez bien. Pour le limon, cependant, le nombre de finesse dépasse la limite de liquidité. Pour les argiles d'une sensibilité > 10, les sols organiques et la bentonite, le nombre de finesse est moins grand que la limite de liquidité.

En déterminant le nombre de finesse, la variation de la résistance au cisaillement selon la teneur en eau a été établie, pour les sols remaniés en état aussi bien plastique que liquide. Une « méthode à un point » pour la détermination du nombre de finesse a été également suggérée.

L'essai au cône a été comparé à l'essai au moulinet, pour quelques sols caractéristiques.

Les résultats dépendent de l'angle au sommet du cône et de l'espèce du sol : peut-être, pour une certaine ouverture dépendent-ils peu du sol.

Les relations tension-déformation, ainsi que les relations résistance au cisaillement-vitesse angulaire ont été traduites par des courbes qui indiquent comment la résistance varie avec les viscosités thixotropique et de structure.

The cone apparatus is shown in principle in Fig. 1. It is provided with test cones weighing 100 grams, 60 grams and 10 grams with cone angles of 30 degrees, 60 degrees and 60 degrees respectively.

The Commission introduced a strength number. It was assumed that the strength at a constant cone impression is directly proportional to the weight of the cone, i.e. to the external work required to produce the impression. The 60 grams-60 degrees cone was chosen as the standard cone. A 10 mm deep impression with this standard cone was given the strength number 10.

The symbol H_1 is assigned to the strength number of the remoulded soil, and H_3 indicates that of the undisturbed sample. The quotient $\frac{H_3}{H_1}$ is a measure of the sensitivity of the soil.

The cone method is an objective and accurate method of determining the "liquid limit" which the Commission defines as "the fineness number".

The fineness number is defined as the moisture content (in percentage of the dry weight) at which the strength number of a remoulded soil sample (H_1 -number) is 10. The

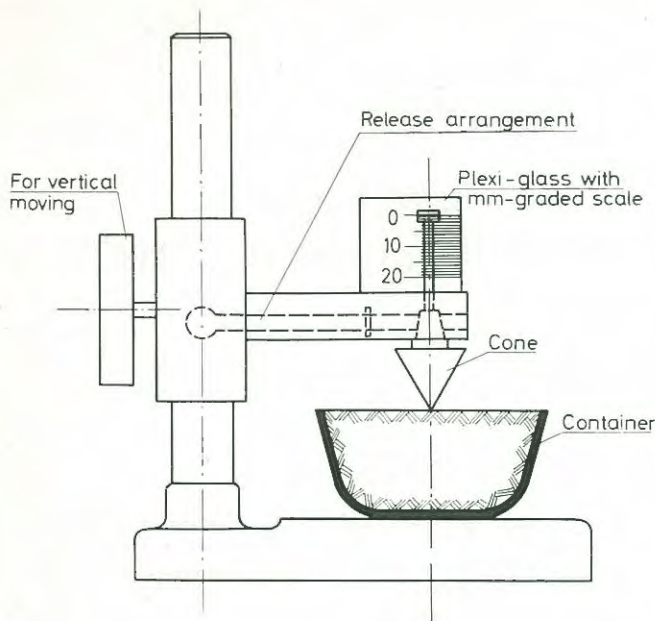

Fig. 1 General arrangement of fall-cone test apparatus.
Schéma de l'appareil d'essai au cône.

Commission developed a "one-point method" for the determination of the fineness number. The H_1 -number of the sample is determined at an arbitrary moisture content, w (as a rule the natural content) and the fineness number, F , is calculated according to the formula :

$$F = \frac{w}{J} \quad \dots (1)$$

where J , which is called the relation number, depends on the H_1 -number in question and also on F . The Commission made a grouping as regards F and worked out and tabulated the relationships between H and J for the respective groups.

Atterberg's method of determining the liquid limit is subjective and wastes a considerable amount of time. The fineness number method is therefore preferred at Swedish geotechnical laboratories.

Atterberg's method was improved considerably by the CASAGRANDE modification (1932). For certain materials, however, particularly dilatant materials, the percussion procedure on which the method is based is unsuitable for the determination of consistency.

The author considers that it is advisable to introduce the fineness number method to an international public, particularly as CASAGRANDE (1958) wished for a method of determining the liquid limit that was superior to the percussion method.

To make comparison of the percussion with the cone method, a large number of samples have been tested at the Swedish Geotechnical Institute. The cone method has also been compared with the laboratory vane.

Consistency Investigations Made

A number of consistency tests were made at the Institute, mainly on Swedi soils, in the first place on clays of different types but also on silt, mud and peat. Tests were also performed on laterite, kaolin and bentonite. The samples of laterite consisted of natural laterite soil from Liberia, while the kaolin and bentonite samples were of normal quality. The samples of kaolin and bentonite were dried when bought; practically all the other samples had their natural water content.

The tests were made at different water contents, the lowest in the vicinity of the plastic limit, and the highest at a semi-fluid consistency considerably higher than the liquid limit.

The kaolin and bentonite were mixed with distilled water until the samples approached the liquid limit, and were then tested. After remoulding, the other samples were first tested at their natural moisture content. Each sample was then divided into two parts. The moisture content of one part was reduced successively and that of the other increased. The moisture content was reduced by spreading the sample on a plaster-of-Paris slab, and increased by adding distilled water.

The cone test was made in a bowl on a partial sample remoulded with a spatula. The water content was determined before and after the tests. In addition to the cones standardized by the Geotechnical Commission, two other cones were employed, one of 400 grams with a 30 degree cone, and the other of 15 grams, with a cone of the same angle.

The percussion liquid limit and the equipment used were according to Casagrande. The hardness of the base of the apparatus (ebonite) was checked by measuring the rebound of a 2 grams steel ball dropped from a height of ten inches (according to CASAGRANDE, 1958 b). The rebound was about 87 per cent of the drop.

The plastic limit was determined according to Atterberg except that the thread of soil was rolled out to a diameter of 3 mm (according to TERZAGHI, 1926).

Relationship between Strength According to the Fall-Cone Method and the Water Content

A new, more theoretical, interpretation of the cone method has been made at the Swedish Geotechnical Institute, HANSBO (1957)*. It was found, under the given experimental conditions, that the following relationship exists between the undrained shear strength, τ_f , and the depth of penetration, h , of a certain cone weight, Q :

$$\tau_f = k \cdot \frac{Q}{h^2} \quad \dots (2)$$

where k depends chiefly on the apex angle of the cone. The value of k was determined by Hansbo by calibration with the field vane.

Comparison now made with a laboratory vane showed, however, that k is dependent on both the apex angle of the cone and the soil proper. For the sake of simplicity, the parameter $\left(\frac{Q}{h^2} = \tau_{par}\right)$, valid for an apex angle of 60°, has

here been used as a measure of strength when plotting the consistency curves (strength of the material to moisture content). Thus k for the 60° cone has been given the value 1. For the 30 degree cone k has been put

$$\left[\left(\frac{Q}{h^2}\right)_{60^\circ} : \left(\frac{Q}{h^2}\right)_{30^\circ} \right]_{av}$$

(see "Comparison of the Cone Method and the Laboratory Vane Method" below).

The consistency curves have been plotted with the strength, τ_{par} , on a log scale and the water content, w , on an arithmetic scale. Figs. 2-4 show the consistency curves of some soil types. In addition to the fineness number, F , the percussion liquid limit, L_L , the plastic limit, P_L , and the natural water content, w_n — where this has been determined — are also shown. F has been indicated at the water contents which, in the consistency curve, is equivalent to $\tau_{par} = 0.06$.

* A similar relation was derived by Terzaghi (1927) but under different conditions.

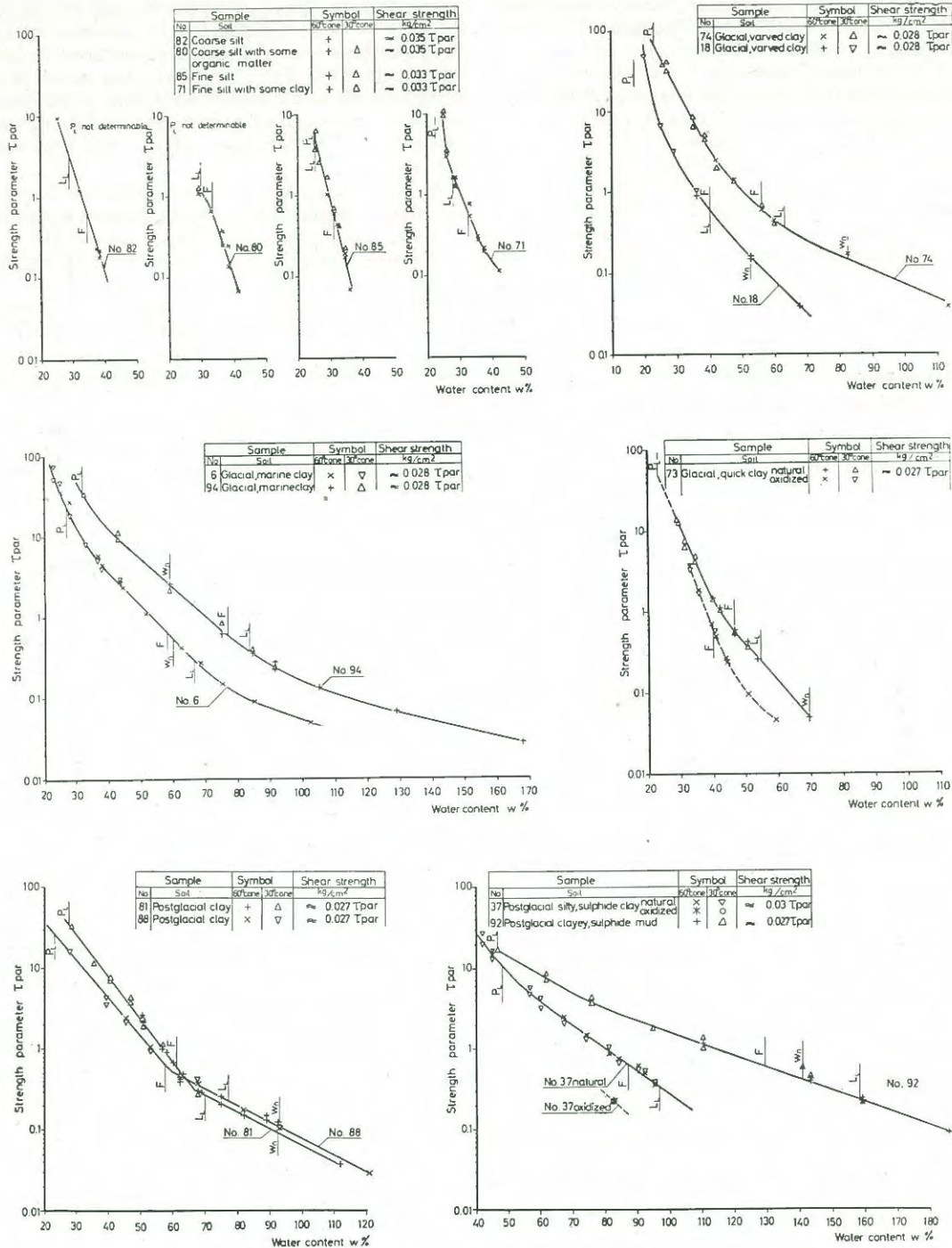

Fig. 2 Consistency curves of some Swedish soils.
Courbes de consistance de quelques sols suédois.

The consistency curve for organic soils is practically rectilinear within the whole of the range investigated. The same is true of silt. The relations for clays is sectionally curved.

Comparison of Casagrande's Flow Curve and the Cone Method, and of the Percussion Liquid Limit and the Fineness Number

When determining the liquid limit, Casagrande plots the relationship between the moisture content, w (in arithmetic scale) and the number of blows, N (in log scale). The curve

(called the flow curve) may, according to Casagrande, be represented by the following equation :

$$w = F_I \cdot \log N + C \quad \dots (3)$$

where F_I = constant, called the flow index
 C = constant.

Thus the flow curve is, when drawn semi-logarithmically, a straight line. The flow index, F_I , is defined as "minus the slope of the semilog plot". This equals the range in moisture

content corresponding to the number of blows, represented by one cycle ($N = 10$ to $N = 100$) on the log scale. The number of blows, may, according to Casagrande, be taken as proportional to the shearing resistance (τ) of the soil.

The flow curve covers only the range near the liquid limit. According to Terzaghi and Janicsek (TERZAGHI, 1931) a similar correlation between τ and w , as represented by Eq. (3), is valid also near the plastic limit. Hence Casagrande assumes that the $w - \log \tau$ relation is represented by a straight line in the whole range between the liquid and the plastic limit.

The toughness index, T_I , is according to Casagrande a measure of the shear strength at the plastic limit and is defined by :

$$T_I = \log \frac{\tau_2}{\tau_1} = \frac{P_I}{F_I} \quad \dots (4)$$

where τ_1 = shearing resistance at the liquid limit, said to be constant for all soils ;

τ_2 = shearing resistance at the plastic limit ;

P_I = plasticity index.

According to the determination made by the cone method, the $\log \tau - w$ relationship (the consistency curve) is generally not rectilinear over the whole range between the liquid and the plastic limit. For some clays the curve is considerably more inclined at the plastic limit than at the liquid limit and in certain cases curved even in the vicinity of the percussion liquid limit. The definitions of the toughness index are then not valid.

In Fig. 5 some typical test results of the fineness number are plotted in addition to the percussion liquid limit, mainly following each other, with certain exceptions.

For very sensitive clays, bentonite and organic soils, the fineness number was smaller than the percussion liquid limit ; for silt, on the other hand, this number was greater, probably due to the fact that silt shows changes in volume and is rather permeable. In determinations made by the percussion method, the surface of the sample is enriched with water and becomes liquid.

If the liquid limit defines a definite strength, it is dependent upon the method used. The shearing resistance at the fineness number and the percussion liquid limit, respectively, has been

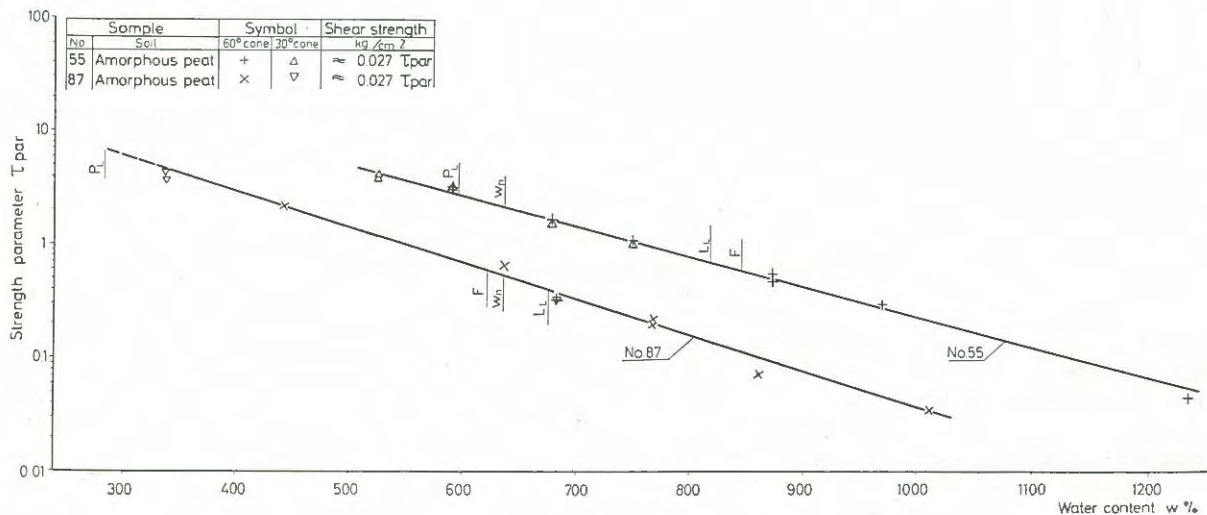
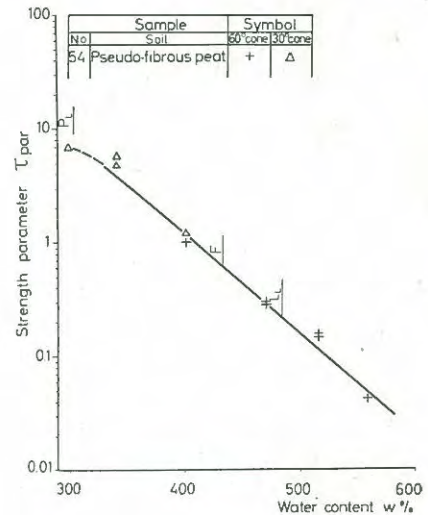
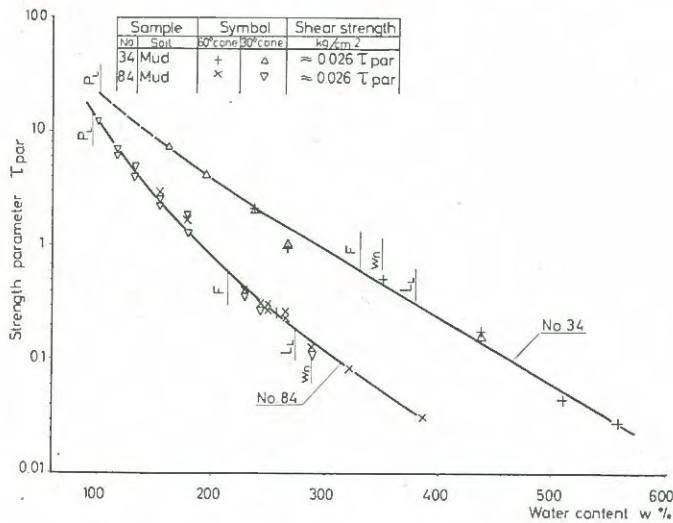

Fig. 3 Consistency curves of some Swedish soils (organic).
Courbes de consistance de quelques sols suédois (organiques).

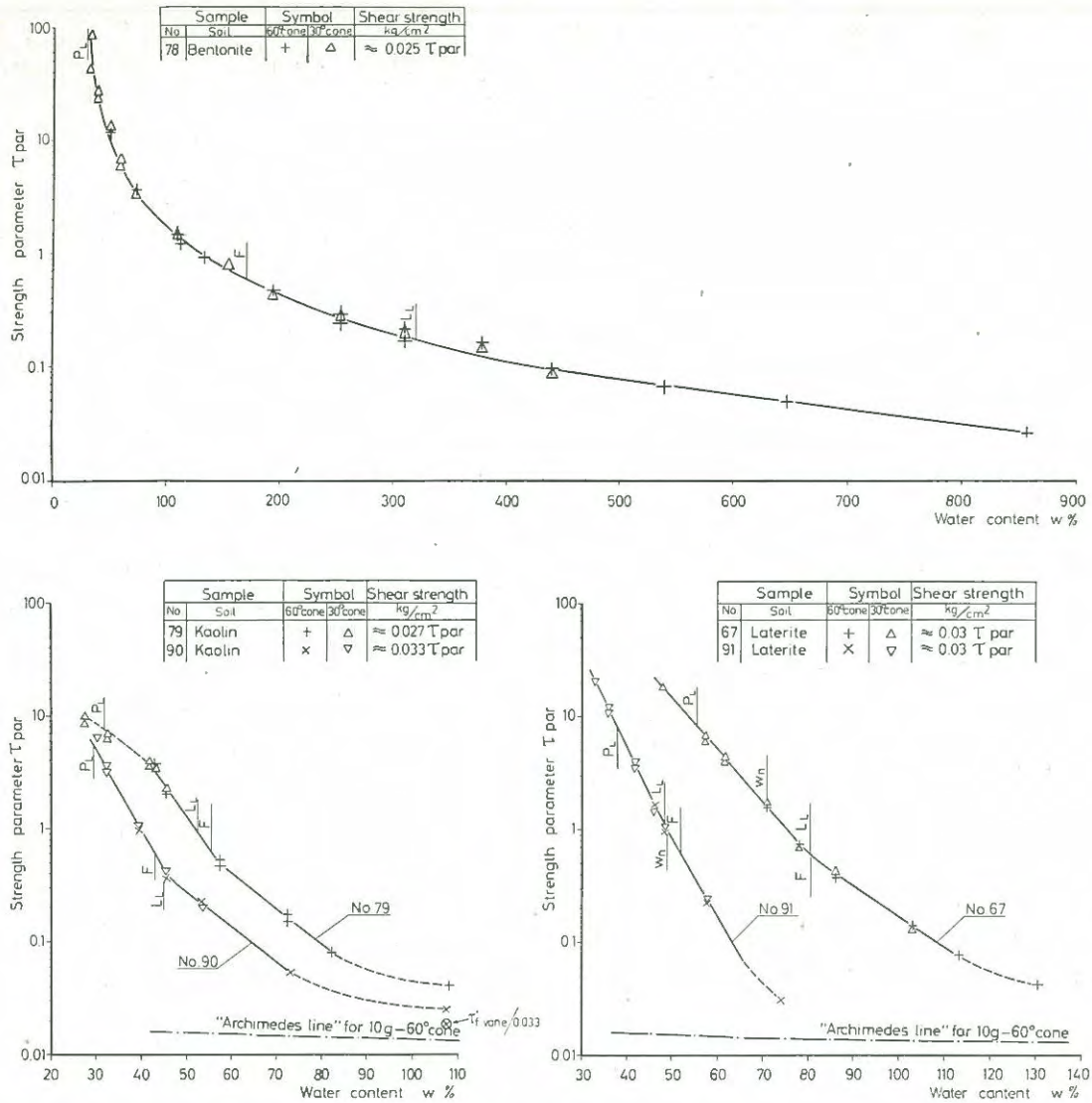

Fig. 4 Consistency curves of bentonite and kaolin (commercial products) and laterite from Liberia.
Courbes de consistance de bentonite et de kaolin (produits commerciaux) et de latérite de Libéria.

determined by the laboratory vane. The values obtained, minimum shearing resistance shown in Table 1, vary widely at the percussion liquid limit and are dependent on the soil. * The variation at the fineness number is small.

One-Point Method for the Determination of Fineness Number

Casagrande's definition of flow index presumes, as mentioned above, a rectilinear relationship between $\log \tau$ and w . For a non-rectilinear curve the flow index, F_I , can be defined according to Fig. 6.

Fig. 7 shows the relationship between the fineness number and the flow index (at the fineness number). Most values are connected to the straight line $A - A$.

The equation for the line $A - A$ is :

$$F_I = \frac{F - 17}{1.8} \dots (5)$$

* Norman (1958) also found a variation in strength of a number of English clays.

Table 1

Apparent shear strength for different soils according to laboratory vane test at percussion liquid limit and fineness number

Sample No.	Soil	Percussion liquid limit LL^* per cent	Fineness number F per cent	Min. shearing resistance Laboratory vane test	
				at LL gr/cm ²	at F gr/cm ²
80	Coarse silt with some organic matter	30	33.5	42	21
81	Postglacial clay	70	61.5	7	16
84	Mud	275	215	5	15
79	Kaolin	52.5	55.5	25	16
90	Kaolin	45	43	15	20
78	Bentonite	320	170	5	15

* According to Casagrande.

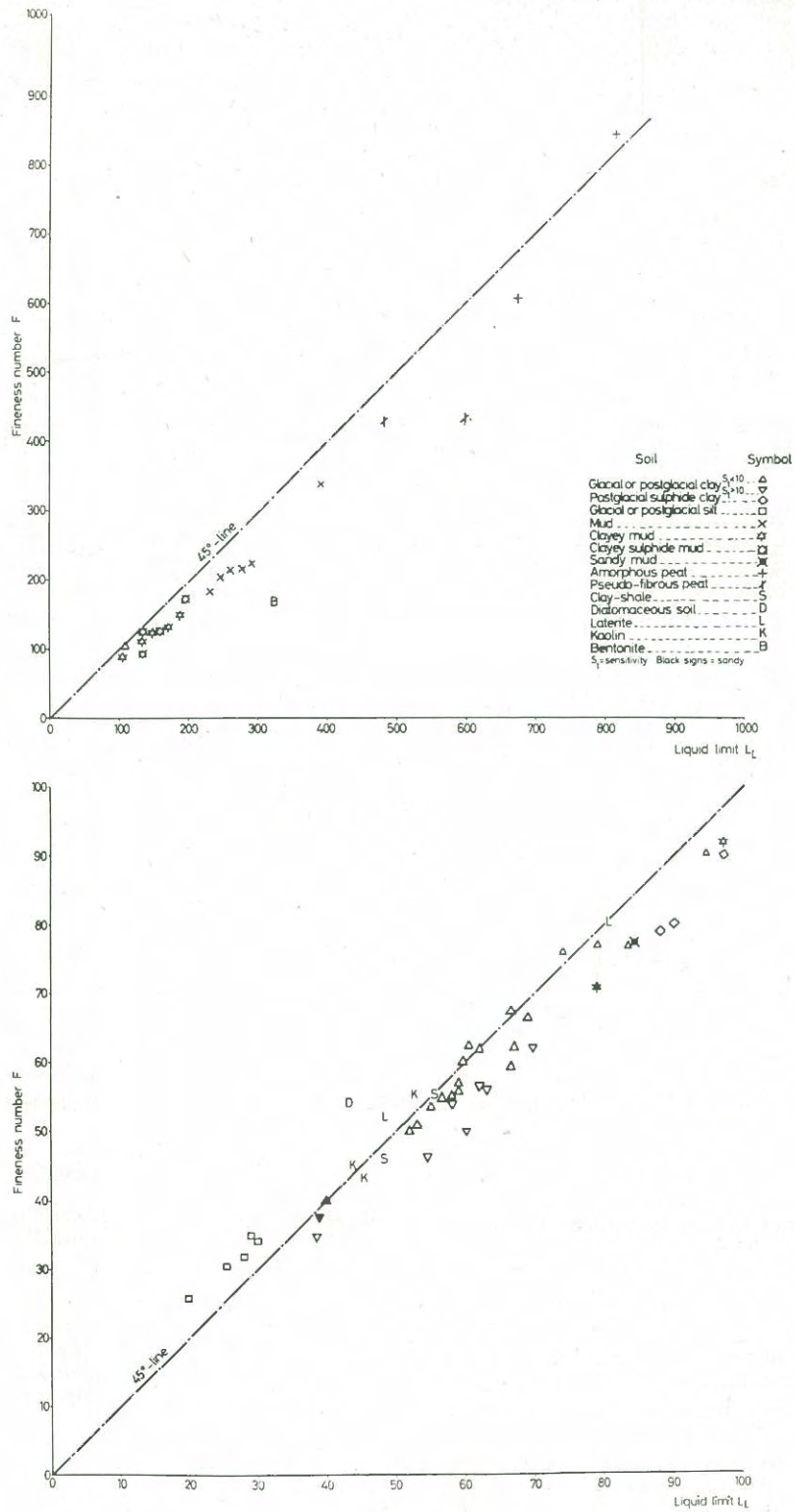

Fig. 5 Comparison between the liquid limit according to Casagrande and the fines number.
 Comparaison entre la limite de liquidité d'après Casagrande et le nombre de finesse.

Fig. 6 Définition of flow index.
Définition de l'indice de liquidité.

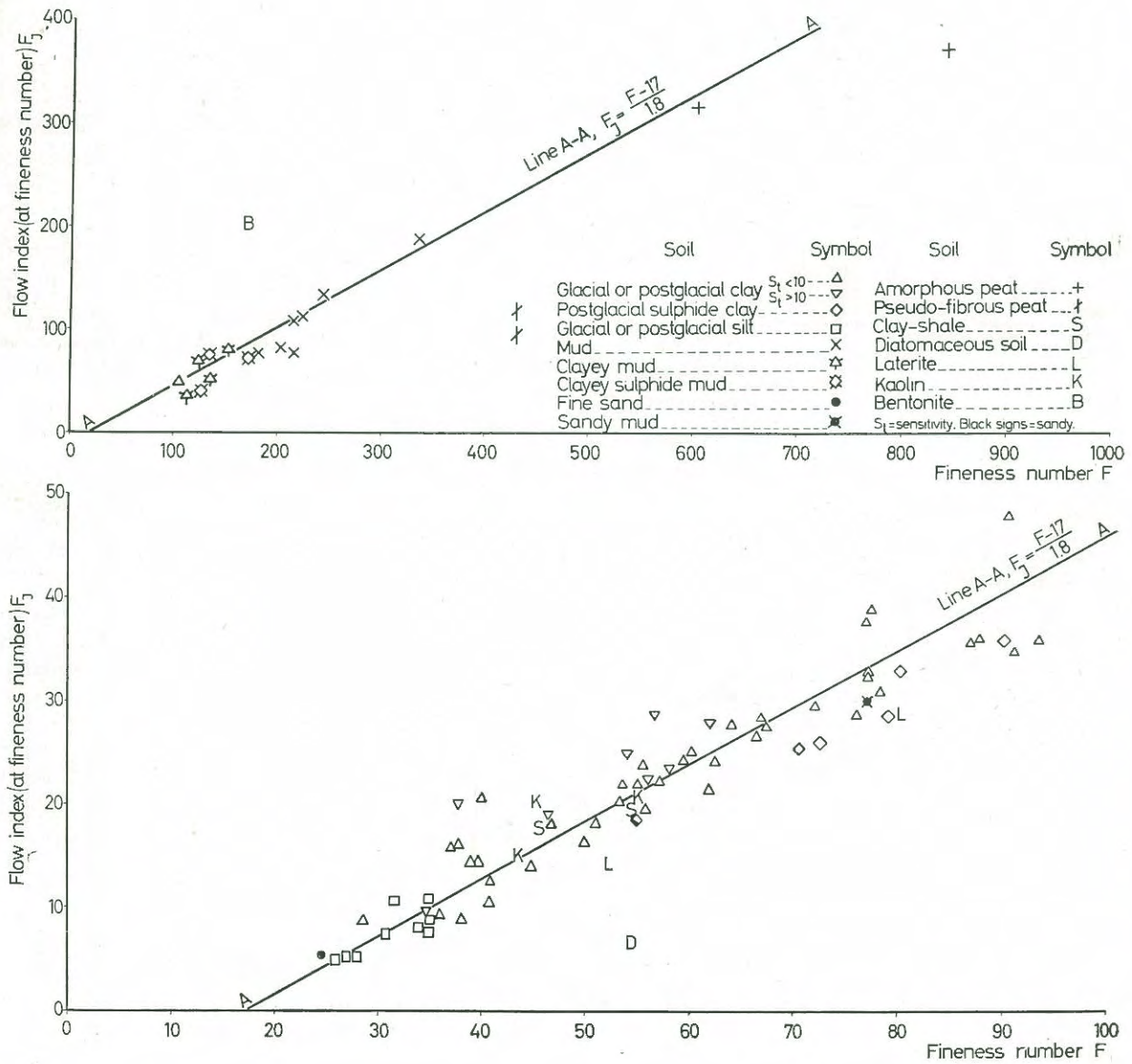
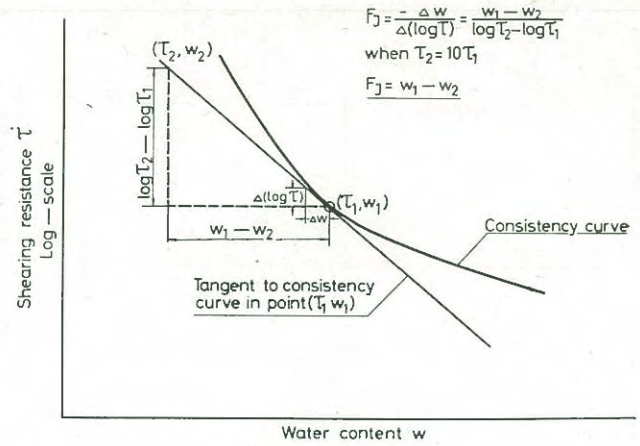

Fig. 7 Correlation between flow index (at fineness number) and fineness number.
Correlation entre l'indice de liquidité (au nombre de finesse) et le nombre de finesse.

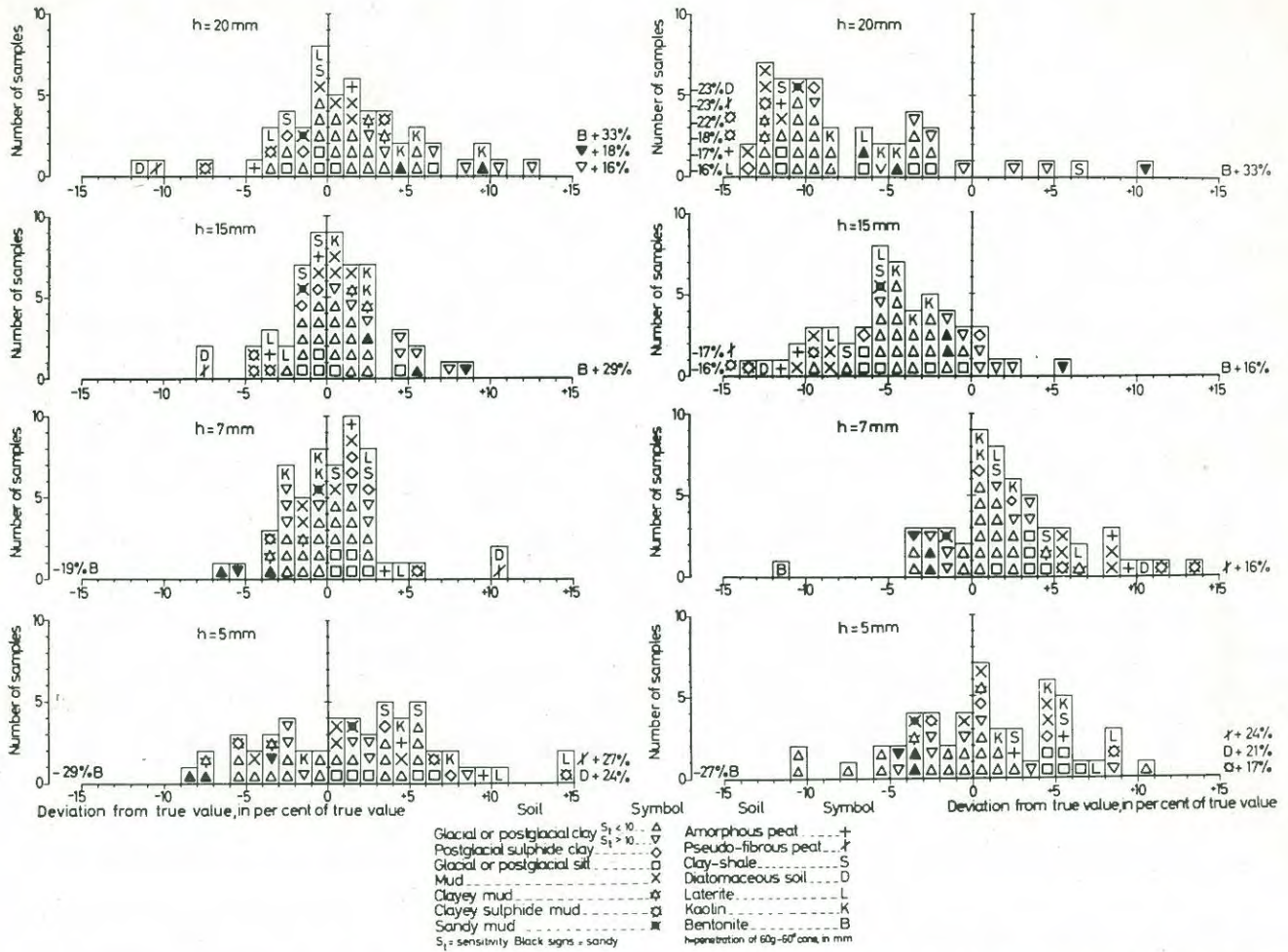

Fig. 8 Deviations from true value for different cone penetration depths at the determination of the fineness number according to the SGI Method and the Geotechnical Commission Method.

Déviations de la valeur vraie relatives à diverses profondeurs de pénétration de cône à la détermination du nombre de finesse selon la méthode SGI et celle de la Commission Géotechnique.

Table 2

Relationship between h , tabulated in tenths of millimetres, M and N , respectively.

M and N are referred to the formula $F = M \cdot w + N$, where F = fineness number at the SGI one-point method and h = cone penetration at the water content w (60 g-60° cone)

h mm	.0	.1	.2	.3	.4	.5	.6	.7	.8	.9	
7	1.21	1.20	1.19	1.18	1.17	1.16	1.15	1.14	1.14	1.13	M
	- 3.5	- 3.4	- 3.2	- 3.0	- 2.9	- 2.7	- 2.6	- 2.5	- 2.3	- 2.2	N
8	1.12	1.11	1.11	1.10	1.10	1.09	1.09	1.07	1.07	1.06	M
	- 2.1	- 1.9	- 1.8	- 1.7	- 1.6	- 1.4	- 1.3	- 1.2	- 1.1	- 1.0	N
9	1.05	1.05	1.04	1.04	1.03	1.03	1.02	1.01	1.01	1.00	M
	- 0.9	- 0.8	- 0.7	- 0.6	- 0.5	- 0.4	- 0.3	- 0.3	- 0.2	- 0.1	N
10	1.00	1.00	0.99	0.99	0.98	0.98	0.97	0.97	0.96	0.96	M
	± 0	+ 0.1	+ 0.2	+ 0.2	+ 0.3	+ 0.4	+ 0.5	+ 0.5	+ 0.6	+ 0.7	N
11	0.96	0.95	0.95	0.94	0.94	0.94	0.93	0.93	0.93	0.92	M
	+ 0.7	+ 0.8	+ 0.9	+ 0.9	+ 1.0	+ 1.1	+ 1.1	+ 1.2	+ 1.3	+ 1.3	N
12	0.92	0.92	0.91	0.91	0.91	0.90	0.90	0.90	0.89	0.89	M
	+ 1.4	+ 1.4	+ 1.5	+ 1.5	+ 1.6	+ 1.7	+ 1.7	+ 1.8	+ 1.8	+ 1.9	N
13	0.89	0.88	0.88	0.88	0.88	0.87	0.87	0.87	0.87	0.86	M
	+ 1.9	+ 2.0	+ 2.0	+ 2.1	+ 2.1	+ 2.2	+ 2.2	+ 2.2	+ 2.3	+ 2.3	N
14	0.86	0.86	0.86	0.85	0.85	0.85	0.85	0.84	0.84	0.84	M
	+ 2.4	+ 2.4	+ 2.5	+ 2.5	+ 2.5	+ 2.6	+ 2.6	+ 2.7	+ 2.7	+ 2.7	N

This relationship may be applied to "one-point determination" of F , on the assumption that the method is restricted to apply within a certain range. If the consistency curve within this range is regarded as a straight line, and the determination is made with a test cone weighing 60 grams and having an angle of 60 degrees, the following relationship will apply :

$$F_I = \frac{w - F}{\log h^2/10^2} \quad \dots (6)$$

where h = the cone penetration at the water content w .

Eqs. (5) and (6) give

$$F = M \cdot w + N \quad \dots (7)$$

$$\text{where } M = \frac{1.8}{1.8 + 2 \log 0.1 h} \quad \text{and} \quad N = \frac{34 \cdot \log 0.1 h}{1.8 + 2 \log 0.1 h}$$

According to the consistency curves the fineness number has been calculated for 56 samples at impressions 5, 7, 15 and 20 mm by the standard cone, using Eq. (7) — called below the SGI method — and according to the Geotechnical Commission method. Divergence from the value of F , according to the consistency curve, has been calculated. The results are shown diagrammatically in Fig. 8.

The SGI method has smaller scattering and the advantage over the Geotechnical Commission method in there is no need to make divisions into groups as regards the fineness number. The method should, however, be restricted to impressions of between 7 and 15 mm with the standard cone. The error for most of the samples tested is then less than ± 5 per cent. For bentonite, diatomaceous soil and semi-fibrous peat multi-point determinations are recommended.

Table 2 shows the relationship between h , M and N , respectively.

For cohesive Swedish soils, the natural moisture content is most usually near the fineness number, and one-point determination can be made at the natural moisture content. Stiff soils and extremely sensitive clays are exceptions, for which multi-point determinations should be made.

Tests Made with the Laboratory Vane

Tests have been made by laboratory vane tests on bentonite, kaolin, postglacial clay, mud and coarse silt.

The vane apparatus used is shown in Fig. 9. Three different vanes with diameters of 1.5, 3.0 and 4.5 cm, respectively, all with a height of double the diameter, were used in the tests. The internal diameter of the sample container was 5.5 cm and the height 17 cm.

Every sample was studied at different moisture contents, both lower and higher than the liquid limit. For each moisture content a series of tests was made at different rotational speeds. In a few tests on bentonite and postglacial clay the rotation speed could be increased by stages from 11 to 1080°/min. In the main tests the rotation speed could be varied gradually between 60° and 30 000°/min.

After the sample had been kneaded in a machine, it was put in the container and then remoulded with a spatula. The table was raised until the upper surface of the vane was 3 cm below the upper surface of the sample. The motor was started, and the strain indicator was read at definite intervals of time during about one revolution. Then the table was disconnected and the container rotated about 50 revolutions ("rotating" remoulding) by hand, after which the test was repeated. Before and after the test, cone tests and determinations of moisture content were made.

Before the speed was altered, the table was lowered and the sample was remoulded with a spatula (normal remoulding). In Fig. 10 is a photograph of the type of failure produced

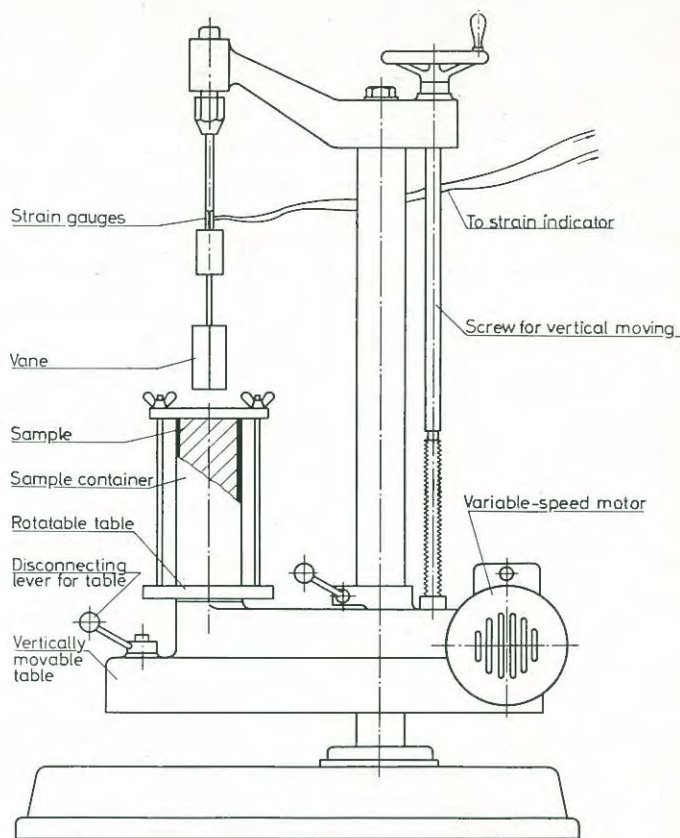

Fig. 9 General arrangement of the SGI vane test apparatus.
Schéma du moulinet SGI de laboratoire.

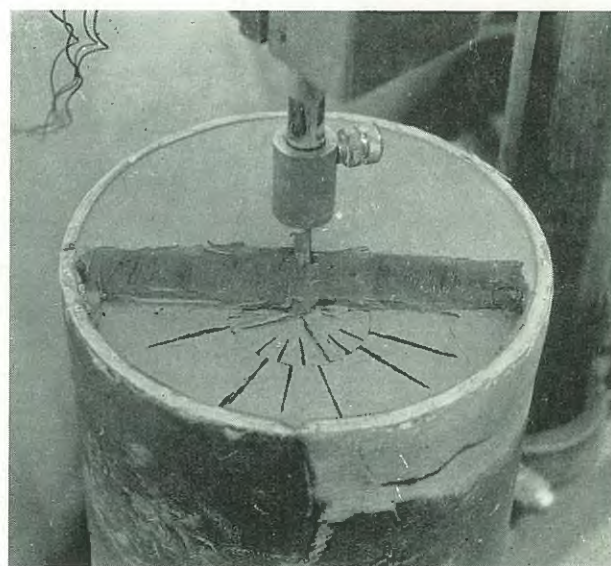

Fig. 10 Surface of rupture at laboratory vane test. Front part of the soil sample cut out to the level of the upper part of the vane. (Radial lines artificially made.)
Surface de rupture pendant un essai de moulinet de laboratoire. Partie antérieure de l'échantillon de sol découpée au niveau de la partie supérieure du moulinet. (Les lignes radiales sont artificielles.)

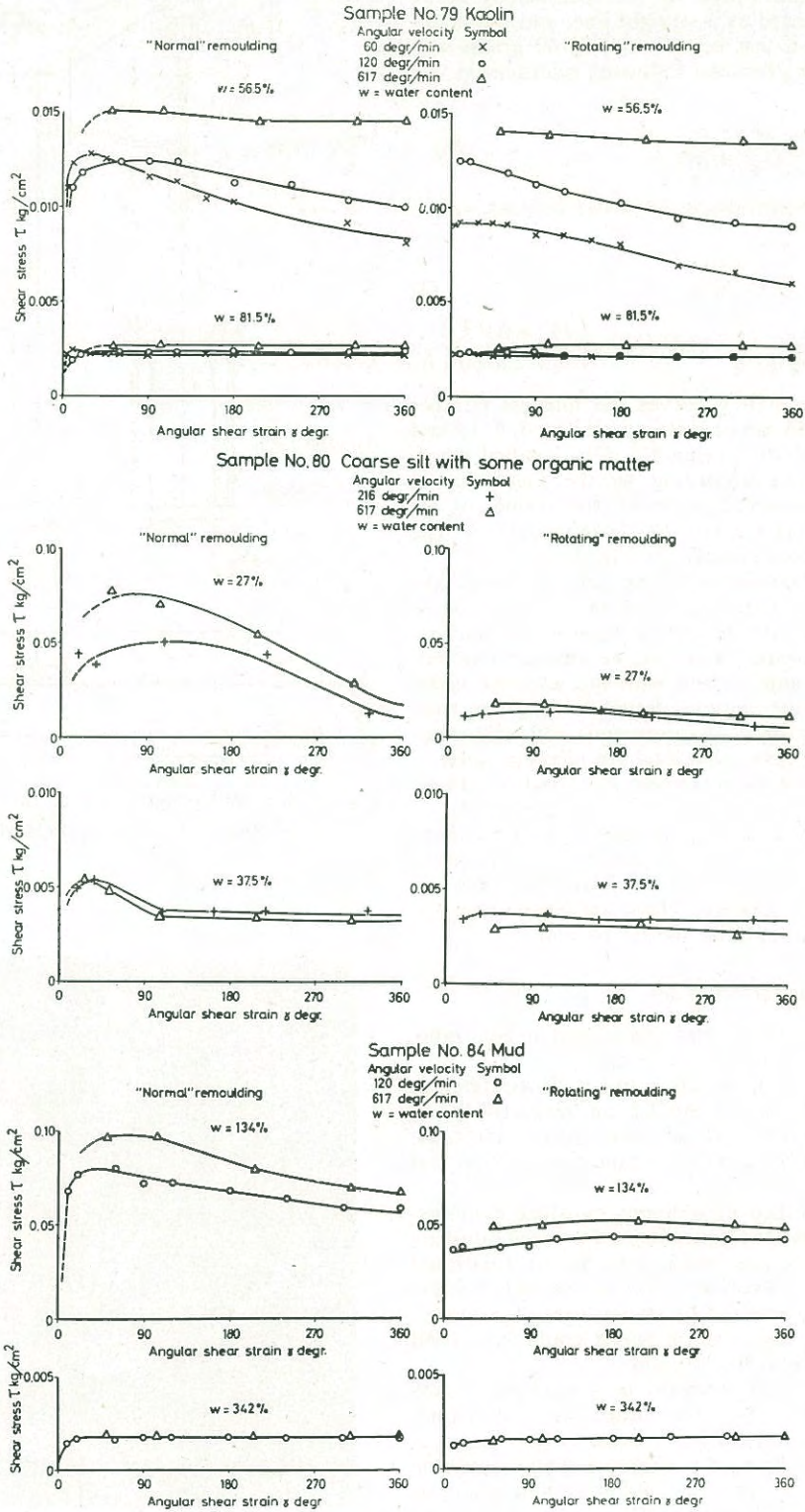

Fig. 11 Typical stress-angular strain curves for various soils at different conditions.

Courbes typiques de contrainte et de déformation anguleuse de sols variés dans des conditions différentes.

by a vane test. This shows that the deformations are mainly concentrated on the failure surface which is typical of all the samples tested.

Stress-Angular Strain Curves

The stress, τ , has been plotted against the angular strain, γ . Typical curves for some of the samples tested are shown in Fig. 11; those in the left part of the Fig. illustrate "normally" remoulded samples, and those in the right part "rotation" remoulded samples.

Tests made on "normally" remoulded bentonite, postglacial clay and coarse silt show that τ , after attaining a maximum, declines with γ and approaches an asymptotic value. The tests made on normally remoulded kaolin and mud show that τ declines with γ only when the water content is lower than the liquid limit. The breakdown of the shearing resistance is probably due to structural viscosity and to thixotropy.

After the same samples had been "rotation" remoulded, the material had practically structural stability, except kaolin with a water content lower than the liquid limit.

Shearing Resistance Angular Velocity Curves

The yield resistance for normally remoulded material has been plotted as a function of the rate of rotation. Fig. 12 shows some such shearing resistances, τ_f , — angular velocity, ω , curves, the latter in log scale.

τ_f has a minimum at rotation rates of 100 to 200°/min. For the evaluation of the cone method, this minimum value has been assumed to represent a measure of the apparent shear strength, and is below called τ_f' .

At higher speeds the τ_f values are largely clustered round a straight line (dashed lines in the Fig.). For velocities higher than those plotted, the values are scattering and falling off from the lines drawn.

To get an idea of the changes in viscosity with the water content of the material, the gradient $\frac{\Delta \tau_f}{\Delta \log \omega}$ may be used

as a measure of the "apparent viscosity". The gradient — water content curve has from tests shown a similar character as the consistency curve.

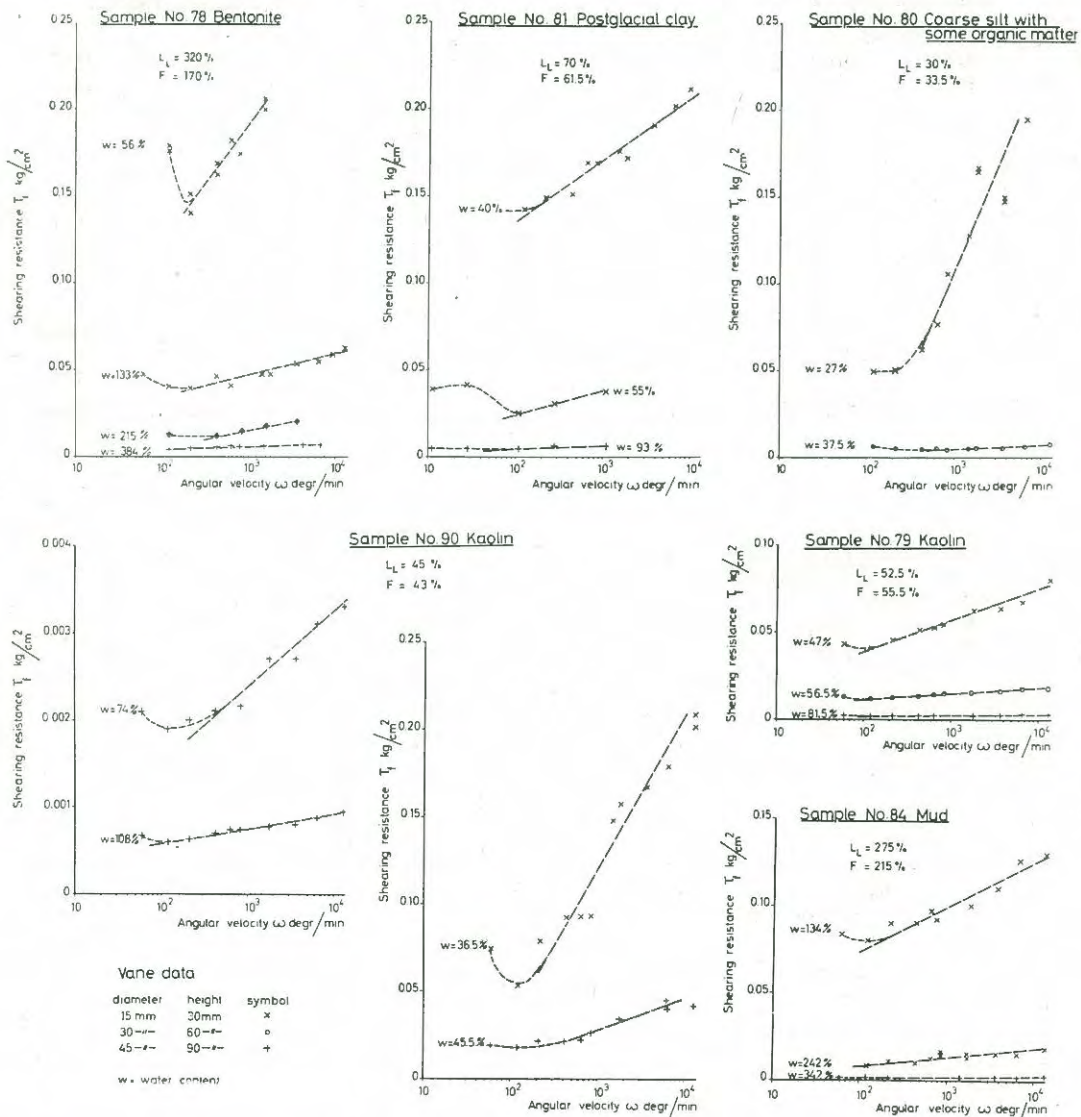
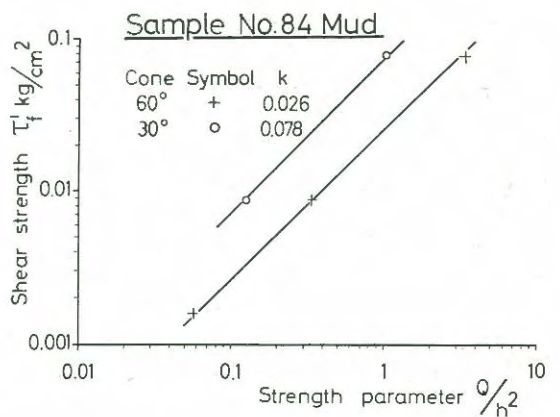
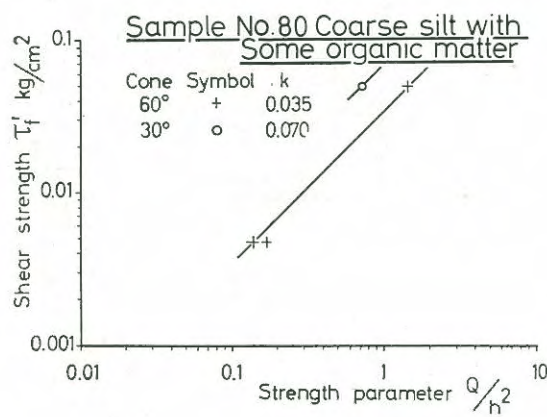
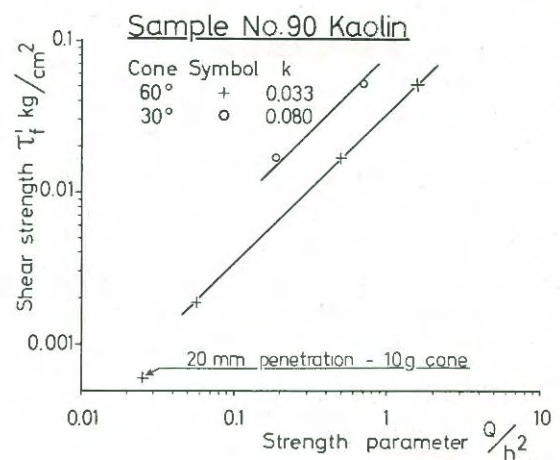
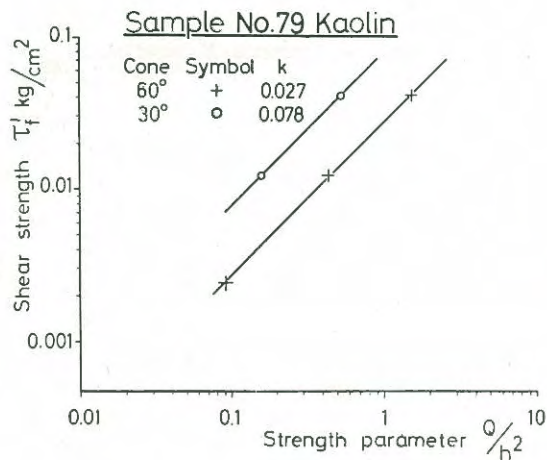
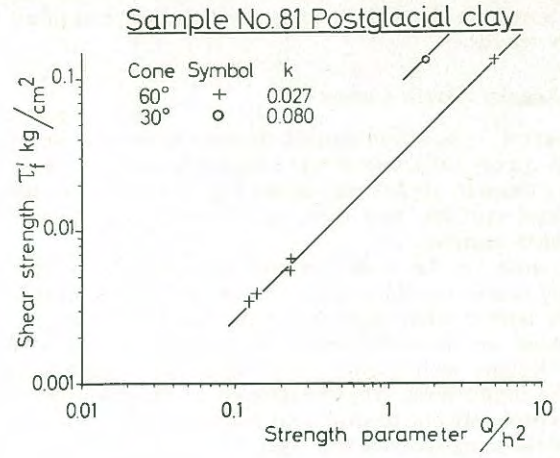
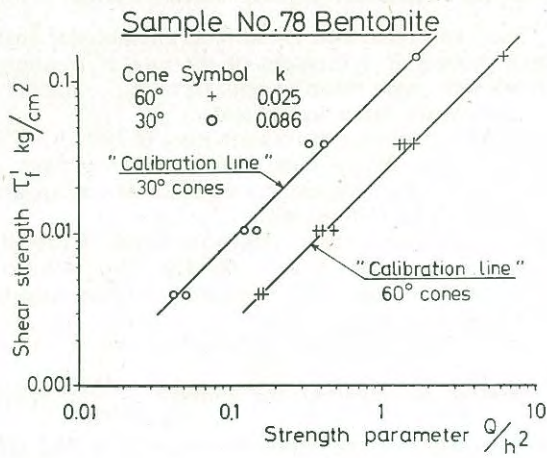

Fig. 12 Typical shearing resistance-angular velocity curves for various soils at different conditions.

Courbes typiques de résistance au cisaillement et de vitesse angulaire de sols variés dans des conditions différentes.



Shear strength T'_f according to laboratory vane test
Strength parameter Q/h^2 according to fall-cone test

Fig. 13 Correlation between shear strength according to laboratory vane test and shear strength parameter $\frac{Q}{h^2}$ at the cone test.

La corrélation entre la résistance au cisaillement selon des essais de moulinet de la boratoire et le paramètre de la résistance au cisaillement $\frac{Q}{h^2}$ relatif à l'essai de cône.

Comparison between the Cone Method and the Laboratory Vane Method

To determine k in Eq. (2), the apparent shear strength, τ_f , according to the vane test, has been plotted against the strength parameter $\frac{Q}{h^2}$ for 30° and 60° cones (Fig. 13),

giving "calibration lines" for the two cones.

According to the test results, the value of k varies with the soil proper. In Fig. 14 a, k has been placed in relation to the plasticity index of the samples examined, and in Fig. 14 b to the parameter quotient

$$\left[\frac{(Q/h^2)_{60^\circ}}{(Q/h^2)_{30^\circ}} \right]_{av.}$$

This quotient is then the mean value of determinations made at a number of different water contents in the same soil sample. The results indicate that, for a certain apex angle between 30° and 60°, the value of k seems only to a slight degree to be dependent upon the soil proper. To investigate this question further tests will also be made with 45° cones.

The value of k also varies to a certain extent with the water content (consistency) for the same soil. Here the value of k has not been determined for water contents below the plastic limit.

Kaolin sample No. 90 was also tested at such a soft consistency that the impression by the 10 gram - 60 degree cone was 20 mm. As shown in Fig. 13, the point representing this test deviates significantly from the "calibration line" used for the evaluation of the cone method.

This certainly depends on the fact that Eq. (2) is not valid at such a soft consistency. The application of Archimedes' principle to cone tests on a soil-water suspension gives :

$$Q = \frac{w/100 + 1}{w/100 + 1/s} \cdot \frac{\pi}{3} \cdot (\tan \beta/2)^2 \cdot \left(\frac{h}{10} \right)^3 \dots (8)$$

where β = apex angle of cone in degrees, and
 s = specific density of dry substance.

As shown in Fig. 4, the consistency curve for kaolin deflects considerably when the cone impression for the 10 gram-cone with a 60-degree angle exceeds 10 to 15 mm. This is mainly valid for a low-plastic soil. Eq. (8), valid for a 10 gram-cone, has been drawn in as an "Archimedes' line" to the consistency curve for kaolin (see Fig. 4). The curve should approach this line asymptotically, providing the determination is made

with a 10 gram-60 degree cone. Thus, a lighter or sharper cone gives a more correct value of the shear strength for very soft soil (in practice, mostly for remoulded quick clays).

In cone tests on remoulded material with a higher moisture content than the liquid limit, a subsequent sinking of the cone occurs. This sinking is of only slight importance at moisture contents near the liquid limit, but increases with the moisture content. As a rule, however, only the instantaneous impression is recorded.

Effect of Certain Factors on the Consistency

Drying may influence the water-retaining capacity, particularly of clays and organic soils (cf. CASAGRANDE 1932 and 1958). Certain soils are also oxidized by the action of air. This refers to soils which have not been exposed to the action of the atmosphere in nature. Among Swedish soils, sulphide clays, muds and quick clays are greatly affected. The value of the liquid limit for a sulphide clay in air may be reduced to less than half the original value. In addition to the original consistency curves for a quick clay and a sulphide clay, Fig. 2 also gives curves for oxidized materials.

The bowls and tools used in the determinations of liquid limit should be made of a material of such a type that there will be no ion exchange.

The result of a determination of consistency depends on the method (apparatus) used, such as by dilatancy, thixotropy and structural viscosity, for example. Thus in field vane tests the remoulded shear strength is determined on "rotated" remoulded material.

Determinations of consistency should be made quickly, mainly to avoid oxidation and stiffening. Care must be taken that the material is completely remoulded. The reduction of the water content by hot air (e.g. by a hairdryer) is unsuitable. If the sample is spread on a slab of plaster-of-Paris, the water is quickly absorbed and no crust is formed on the surface of the sample. The slab of plaster must be smooth so that the sample can easily be detached from it. The salt concentration in the pore water of salty clays is increased if the moisture content is reduced by evaporation.

Views on the Practical Application of the Consistency Curve

The consistency curve of a given soil shows definite characteristic features. The curve, therefore, may be helpful in the classification of soils. Hitherto at SGI, curves have been determined only at higher moisture contents than the plastic

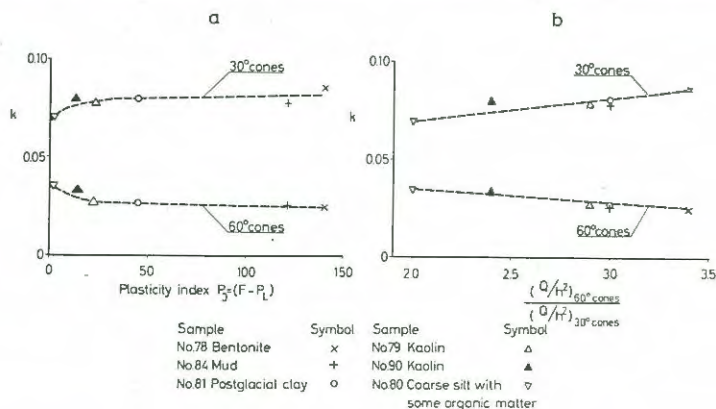

Fig. 14 Influence of the soil material on the value of k in the Hansbo formula $\tau_f = k \frac{Q}{h^2}$ cone test.

L'influence de la nature du sol sur la valeur de k dans la formule de Hansbo $\tau_f = k \frac{Q}{h^2}$ résultant de l'essai de cône.

limit.* If the curve is also determined at lower moisture contents, it should provide a better characterization of the soil in question.

The consistency curve (flow index) should also be useful in an approximate determination of certain physical properties of natural soil, e.g. the compressibility and the increase of shear strength with consolidation pressure (the sensitivity taken into consideration). The investigation at SGI of this problem has only just been commenced, however. The tests made hitherto show that the oedometer curve (here plotted as the relationship between pressure and water content) for the undisturbed sample has a course similar to that of the consistency curve of the remoulded samples, providing the sample is normally consolidated. When, for example, the consistency curve deflects, the oedometer curve also deflects.

Acknowledgements

The Author wishes to thank Mrs. A. Schöldström of the Institute, for valuable help in the performance of the laboratory tests.

References

- [1] ATTERBERG, A. (1911). Über die physikalische Bodenuntersuchung, und über die Plastizität der Tone. *Internat. Mitt. Bodenk.*, Vol. 1.
 [2] — (1913). Die Plastizität und Bindigkeit

* Atterberg (1916) has determined consistency curves at lower water content than the plastic limit, but not higher than the sticky limit. Atterberg determined the strength (consistency number) by splitting prisms of soil with a loaded steel wedge. Compare also S. Johansson (1913).

- liefernden Bestandteile der Tone. *Internat. Mitt. Bodenk.*, Vol. 3, pp. 291-330.
 [3] — (1914). Die Konsistenzkurven der Mineralböden. *Internat. Mitt. Bodenk.*, Vol. 4, pp. 418-432.
 [4] — (1916). Konsistenzläran—en ny fysikalisk lära. *Sv. Kem., Ts.* 28, pp. 29-37.
 [5] CALDENIUS, C. et LUNDSTRÖM, R. (1956). The Landslide at Surte on the River Göta Älv. *Sv. Geol. Unders. Ser. Ca*, No. 27, pp. 30-36, Stockholm.
 [6] CASAGRANDE, A. (1932). Research on the Atterberg limits of soils. *Public Roads*, Vol. 13, No. 8, pp. 121-130, 136.
 [7] — (1958 a). Notes on the Design of the Liquid Limit Device. *Géotechnique*, Vol. 8, No. 2, pp. 84-91.
 [8] — (1958 b). Communication to various institutions.
 [9] GEOTECHNICAL COMMISSION OF THE SWEDISH STATE RAILWAYS, 1914 to 1922 (1922). Final Report. *Stat. Järnv. geot. Meddl.*, No. 2, Stockholm.
 [10] HANSBO, S. (1957). A New Approach to the Determination of the Shear Strength of Clay by the Fall-Cone Test. *Sw. Geot. Inst. Proc.*, No. 14, Stockholm.
 [11] JOHANSSON, S. (1914). Die Festigkeit der Bodenarten bei verschiedenem Wassergehalt nebst Vorschlag zu einer Klassifikation. *Sv. Geol. Unders. Ser. C*, No. 256, Stockholm.
 [12] NORMAN, L. E. J. (1958). A Comparison of Values of Liquid Limit Determination with Apparatus Having Bases of Different Hardness. *Géotechnique*, Vol. 8 No. 2, pp. 79-83.
 [13] TERZAGHI, K. (1926). Simplified Soil Tests for Subgrades and their Physical Significance. *Public Roads*, Vol. 7, No. 8, pp. 153-162, 170.
 — (1927). Determination of Consistency of Soils by Means of Penetration Tests. *Publ. Roads*, Vol. 7, No. 12, pp. 240-247.
 [15] — (1931). Festigkeitseigenschaften der Schüttungen, Sedimente und Gele. *Handbuch der physikalischen und technischen Mechanik*. Vol. 4, P. 2, pp. 513-573, Berlin.