

ROYAL SWEDISH
GEOTECHNICAL INSTITUTE
PROCEEDINGS
No. 13

PORE WATER PRESSURE
MEASUREMENT IN FIELD
INVESTIGATIONS

By

TORSTEN KALLSTENIUS and
ALF WALLGREN

STOCKHOLM 1956

ROYAL SWEDISH
GEOTECHNICAL INSTITUTE
PROCEEDINGS
No. 13

PORE WATER PRESSURE
MEASUREMENT IN FIELD
INVESTIGATIONS

By

TORSTEN KALLSTENIUS and
ALF WALLGREN

STOCKHOLM 1956



Ivar Haggströms Boktryckeri AB
Stockholm 1957

Contents

Preface	5
§ 1. Fundamental Considerations	7
1 a. Requisite Accuracy of Measurements	7
1 b. Time Lags	8
1 b 1. Installation Time Lag	8
1 b 2. Measurement Time Lag	10
1 c. Time Lag in Practice	13
1 c 1. Filter Design	14
1 d. Special Considerations on Pore Pressure Meter Design	15
§ 2. Early Hydraulic Meters of the Institute	15
2 a. "Väsby" Meter	15
2 b. "Surte" Meter	17
2 c. Experience with First Hydraulic Meters	20
§ 3. First Electro Pneumatic Meter of the Institute	24
3 a. Principles	24
3 b. Design and Use	26
§ 4. SGI Pore Pressure Measuring System	30
4 a. Principles	30
4 b. Instrument Connection	31
4 c. Filter Pipe	34
4 c 1. Design	34
4 c 2. Filter Pipe in Practice	35
4 d. Oil-Filled Pick-Up	37
4 d 1. Principles	37
4 d 2. Design and Construction	38
4 e. Electro Pneumatic Pick-Up	43
4 e 1. Principles	43
4 e 2. Design and Construction	44
4 f. Recording Instruments	47
4 f 1. Ink Recorder	47
4 f 2. Optical Recorders	47
4 g. Experience with SGI System	49
§ 5. Precision Pick-Up	54
§ 6. Conclusions	57
§ 7. Summary	58

Preface

This report contains a description of the development of pore water pressure meters at the undersigned Institute during the period from 1947 to 1955 carried out by the Mechanical Department under the direction of its head, Mr Torsten Kallstenius, who prepared this report.

During the years 1948 to 1950, Mr Henry Ericsson, former Assistant Head, Mechanical Department, was in charge of construction and tests. After that his successor, Mr Alf Wallgren, continued this work.

Stockholm, June, 1956

ROYAL SWEDISH GEOTECHNICAL INSTITUTE

§ 1. Fundamental Considerations

Determination of pore water pressure is nowadays generally known to be important in correct solutions of many geotechnical problems, *e.g.*, in dealing with the stability of foundations, earthworks, heavy storages, and soil slopes, which can be influenced by this pressure. Further, consolidation processes and seepage can be observed by means of pore water pressure measurements.

Therefore, pore water pressure measurements should also be included in routine field investigations.

This report deals with the development of the meters and the methods of measurement used by the Institute in its field investigations, which are mostly made in clays.

In our investigations, the pore water pressure meters are provided with filter points at the ends of pipes, which are more or less vertically installed. The filter points permit the pore water to move freely, while they keep the soil away from the measuring elements.

§ 1. a. Requisite Accuracy of Measurements

The requisite accuracy of pore pressure measurements is determined by the problem to be solved. From this point of view, we can distinguish between two main types of problems.

The first type does not generally require high accuracy. In problems of this type, the results are influenced by many factors other than the pore pressure. Some of these factors are of statistical nature. An example is the ordinary stability calculation when it is based upon sampling and determination of stratification, *etc.* It is evident that many of the factors involved in this case cannot be determined exactly. A final result within an accuracy of, say, $\pm 5\%$ would at present be regarded as very satisfactory. In problems of this type a pore pressure determination within similar limits of accuracy, referred to the depth of the meter point below ground level, is quite sufficient.

The second type of problem, which requires high accuracy or sensitivity, deals with pore pressure alone. In such cases, if the problem is influenced by any other factors, they are either empirically known or of secondary interest.

The second type may be exemplified by an area where the limit of stability has been indicated by slides caused by excess pore pressure. Here the changes in pore pressure should be measured very accurately. This requires an instrument that is sensitive to small changes. We should generally be satisfied with a sensitivity of, say, one per cent of the water pressure corresponding to the depth of the meter point below ground level. Another example is the determi-

nation of ground water seepage by means of pore pressure measurements in several points along a line. In that case, great accuracy is needed in order that different measurements may be combined so as to determine water-level gradients.

In problems of the latter type, only a high sensitivity is sometimes desired but sometimes the requisite absolute accuracy must also be higher than in problems of the first type.

We can specify our requirements as follows:

1) An ordinary pore pressure meter should be able to measure the pore pressure within an accuracy of $\pm 5\%$ of the depth of the meter point below ground level, and should have a sensitivity that is about five times as high. Such a meter would be sufficient for most geotechnical problems. In practice, it should be simple and rugged.

2) A precision pore pressure meter will be needed only for special problems of the above-mentioned second type or for research purposes. Its accuracy and sensitivity should be as high as possible. In order to ensure this, it may be necessary that the meter should be used by specialists in measurements.

§ 1 b. Time Lags

Important factors in the design of pore pressure meters are the time lags which affect the measurements in low-permeability soils. These lags are of two different kinds. We shall call them "installation time lag" and "measurement time lag". Hvorslev has dealt with these questions in some reports^{1 2} which also contain bibliographies.

§ 1 b 1. Installation Time Lag

The pore pressure meter pipes can be installed in two fundamentally different ways. Either a hole is bored in the ground, and the meter is installed and sealed in this hole (*cf.* Ref. 1, p. 78—81), or the meter is pressed axially into the ground. In both cases the natural pore pressure is very much disturbed. In the former method, the influence of the installation upon the pore pressure is dependent on the method of hole boring and the pore pressure can be either increased or decreased. If the pore pressure is in excess in some thin layer, there is a danger of break-through from this layer to the neighbouring pervious layers. In some cases such a break-through cannot be sealed afterwards. When the pipe is pushed down, the danger of break-through is small, but on the other hand the initial pore water overpressures near the meter point are very high. The Institute normally prefers the latter method, which is dealt with in what follows.

¹ Hvorslev, M. Juul, Subsurface Exploration and Sampling of Soils for Civil Engineering Purposes. Vicksburg 1948. (U.S. Waterways Exper. Stat.)

² Hvorslev, M. Juul, Time Lag and Soil Permeability in Ground Water Observations. Vicksburg 1951. (U.S. Waterways Exper. Stat. Bull. No. 36.)

To estimate the excess pore pressure we may consider the idealized case of a solid rod with the radius R_o cm penetrating into a medium having the modulus of elasticity E kg/cm². From the theories of elasticity and plasticity one can deduce expressions for the interior pressure σ_{\max} required to increase the radius of a very small spherical or cylindrical hole to the radius R_o . Such expressions have been given by several authors. Odenstad¹ has applied the theories also for a sensitive material where the shear strength τ_f is decreased to the value $\alpha \cdot \tau_f$ in the plastic zone which surrounds the spherical hole. For the spherical case the pressure should be

$$\sigma_{\max} = \tau_f \cdot \frac{4}{3} \left(\alpha \ln \frac{E}{3 \tau_f} + 1 \right) \dots \dots \dots (1)$$

According to this expression σ_{\max} should be independent of the radius R_o . A numerical evaluation of Eq. (1) is dependent on the choice of the apparent modulus of elasticity E which in its turn ought to be dependent on, *e. g.*, the pore water flow.

If we put $\frac{E}{3 \tau_f} = 1000$ and $\alpha = 1$ we obtain

$$\sigma_{\max} \approx 10 \tau_f \dots \dots \dots (2)$$

which is of the same order as the so-called N_c -value.²

In a saturated clay the corresponding initial excess pore pressure ought to be slightly less than the value σ_{\max} given above. Eq. (1), however, does not include such influences as dynamis forces, skin friction, gases in the soil, *etc.* In a clay with $\tau_f \approx 0.3$ kg/cm² we have measured initial excess pore pressures of the magnitude of 2.5 kg/cm² which would give $\sigma_{\max} \approx 8 \tau_f$.

The zone of excess pore pressure will, in practice, extend to a boundary situated at a certain distance from the rod. From theory it can be inferred that the radius of this zone is roughly proportional to the radius of the rod or pipe.

After the pipe has been installed, a consolidation process begins. This causes pressure gradients, which generally decrease with the time. The time required in order that the excess pore pressure shall decrease to a certain definite value is the "installation time lag". This value depends on the problem and corresponds to the requisite accuracy; in other words, it depends on the permissible error in measurements.

The consolidation time varies within wide limits with many factors. Therefore, we have confined ourselves to a few simple tests.

Fig. 1 shows the results of an experiment made to find out the installation time lag as a function of the diameter of the pipe. Two pipes, which were different in diameter but equal in filter area, were pushed down 10 metres into a saturated clay having a permeability of $\sim 10^{-8}$ cm/sec. Pore pressure measure-

¹ S. Odenstad, Spänning och deformation i en oändlig rymd (Stress and Deformation in an Infinite Space). Stockholm 1951. Unpublished.

² See, for instance, E. G. Meyerhof: The Ultimate Bearing Capacity of Foundations. — Géotechnique 1951 Vol. 2 Nr 4 p. 301—332.

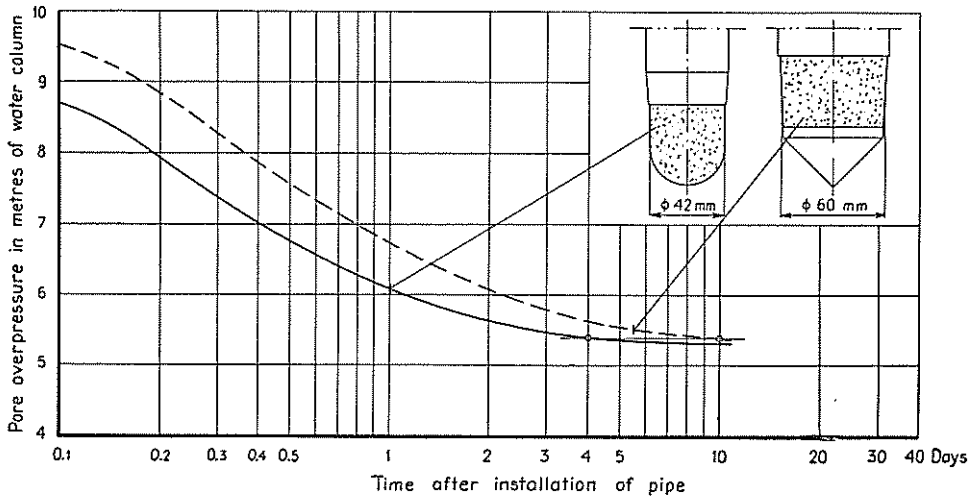

Fig. 1. Test for determination of installation time lag.

ments were made with identical interior systems. Thus the difference between the observed values gives the difference in time lag. We notice that equal pressures are obtained after four days with the $\phi 42$ mm pipe and ten days with the $\phi 60$ mm pipe. This seems to indicate that the influence upon the time lag is roughly proportional to the square of the pipe diameter. We also tried to keep the interior of the pipe open to facilitate consolidation, but the effect was not very noticeable.

Installation time lags varying from a few minutes to two weeks have been observed in practice.

In cases where the installation time lag is of great importance, the diameter of the meter point and the diameter of the parts of the meter close to this point should be as small as possible.

§ 1 b 2. Measurement Time Lag

The amount of energy which is required for measurements is in the present case taken from the pore water which must enter or leave the pore pressure meter when the pore pressure changes. As the pore water flows through the soil, pressure losses will arise. They cause gradients, which will gradually decrease if all other conditions remain unchanged.

These pressure losses determine that maximum rate of pore pressure change with the time at which the meter gives an indication that is correct within a desired accuracy. A theory¹ specially adapted to our requirements is briefly expounded in what follows.

¹ Deduced in co-operation with Mr. Justus Osterman, Head of the Institute.

We suppose that a soil is saturated with water, is free from gases, and has a pore pressure = u_s g/cm². We assume a pore pressure meter to be installed in this soil and to give, at a certain definite moment a pressure reading u_i g/cm². We put

$$u_s - u_i = \Delta u \dots\dots\dots (3)$$

where obviously Δu is the error, in g/cm². In many cases, u_s may be regarded as constant, but it is mostly variable with the time (t)

$$u_s = f(t) \dots\dots\dots (4)$$

From Eqs. (3) and (4) we obtain by differentiation with respect to the time

$$\frac{\partial \Delta u}{\partial t} = \frac{\partial f(t)}{\partial t} - \frac{\partial u_i}{\partial t} \dots\dots\dots (5)$$

If the pore water volume entering the meter per unit time is V_u cm³/sec, and if the meter requires the volume Θ cm³ to alter its reading one g/cm² (Θ is by us called "volume factor", and has thus the dimension cm⁵/g), then we obtain

$$V_u = \frac{\partial u_i}{\partial t} \cdot \Theta \dots\dots\dots (6)$$

In the soil around the meter point, the flowing pore water causes certain pressure losses, which give the pressure gradient

$$i = \frac{\partial \Delta u}{\partial r} = \frac{v}{k} = \frac{V_u}{k \cdot A_r} \dots\dots\dots (7)$$

where v is the flow velocity, in cm/sec, k is the coefficient of permeability, in cm⁴/g sec., r is the distance, in cm, from the meter point to a certain definite soil element, and A_r is the area, in cm², of a sphere with the radius r . We consider the filter area (A) to be represented by an equivalent radius r_o . Thus $A = 4 \pi r_o^2$.

Further, we assume the soil layer to have large dimensions. The water flowing to the meter is assumed to come from a great distance. These assumptions are allowable, as we intend only to form an estimate of the measurement time lag.

From Eq. (7) we obtain

$$\Delta u = \frac{V_u}{4 \pi \cdot k} \cdot \int_{r_o}^{\infty} \frac{dr}{r^2} \dots\dots\dots (8)$$

Combining Eqs. (6) and (8) gives

$$\Delta u = \frac{\Theta}{2k \sqrt{\pi A}} \cdot \frac{\partial u_i}{\partial t} \dots\dots\dots (9)$$

By combining Eqs. (5) and (9), we get

$$\frac{\partial \Delta u}{\partial t} + \frac{2k \sqrt{\pi A}}{\Theta} \cdot \Delta u = \frac{\partial f(t)}{\partial t} \dots\dots\dots (10)$$

From Eqs. (3), (5), and (10) we can immediately find the pore pressure ($= u_s$):

$$u_s = u_i + \frac{\Theta}{2k\sqrt{\pi A}} \cdot \frac{du_i}{dt} \dots \dots \dots (10 a)$$

Eq. (10 a) makes it clear that the meter will indicate the pore pressure in the soil correctly at maxima or minima in u_i . This does not mean that the maxima and minima of u_s are obtained directly, but they can be calculated from Eq. (10 a).

By solving Eq. (10), we get the general expression

$$\Delta u = \left[(\Delta u)_{t=0} + \int_0^t \frac{\partial f(t)}{\partial t} \cdot e^{\frac{2k\sqrt{\pi A}}{\Theta} \cdot t} \cdot dt \right] e^{-\frac{2k\sqrt{\pi A}}{\Theta} \cdot t} \dots \dots \dots (11)$$

We are now particularly interested in two special cases. Firstly, there is the case where u_s is constant, while, at the time $t=0$, u_i differs from this value by Δu_0 . Here we can calculate the time T , in seconds, corresponding to a certain maximum permissible error Δu_T . T can be regarded as the "measurement time lag" in this case. Eq. (11) can then be transformed into

$$T = \frac{\Theta}{2k\sqrt{\pi A}} \cdot \ln \frac{\Delta u_0}{\Delta u_T} \dots \dots \dots (11 a)$$

Secondly, there is the case where we want to know the maximum permissible rate of change $\frac{\partial u_s}{\partial t}$ at which Δu is less than the permissible error Δu_T . We can obtain a simple solution if we assume that the pore water flow is constant, i.e., $\Delta u = \Delta u_T = a$ constant.

By solving Eq. (11), we obtain

$$\Delta u_T = \frac{du_i}{dt} \cdot \frac{\Theta}{2k\sqrt{\pi A}} \dots \dots \dots (11 b)$$

which is closely related to Eq. (10 a). This expression—although a simplification—is useful if we have plotted a diagram representing the pore pressure as a function of the time, and if we want to know whether the meter has been sufficiently responsive.

From Eqs. (11 a) and (11 b) we find that the time lag in saturated soils which are free from gases is determined by the instrument $\left(\frac{\Theta}{2\sqrt{\pi A}} \right)$, by the soil (k), and by the type of problem (Δu_T).

It may be useful to illustrate Eqs. (11 a) and (11 b) by some calculations. Let us, for instance, compare the cases below.

- Case I An open pipe, 6 cm in outer diameter and 5 cm in inner diameter, combined with a filter, 6 cm in diameter and 30 cm in height.
- Case II The same device as in Case I, except that the inside diameter is decreased to one cm.
- Case III The same device as in Case II, except that the inner system is closed and the measurements are made with a Bourdon gauge.
- Case IV The same device as in Case III, except that the height of the filter is decreased to 5 cm.

In all these cases we measure in a clay with $k = 10^{-8}$ cm⁴/g sec. (or cm/s).
The calculation is given in the table below.

Case	Volume factor θ cm ³ /g	$2\sqrt{\pi A}$ cm	Δu_T g/cm ²	$\frac{du_i}{dt}$ g/cm ² sec	Time lag T for $\Delta u_o = 40$ g/cm ²
I	19.5	84	20	$0.86 \cdot 10^{-6}$	186 days
II	0.78	84	20	$0.22 \cdot 10^{-4}$	7.4 days
III	$3 \cdot 10^{-4}$	84	20	$0.56 \cdot 10^{-1}$	4.1 min.
IV	$3 \cdot 10^{-4}$	34.3	20	$0.23 \cdot 10^{-1}$	10 min.

This table shows that the open pipe in Case I can hardly be used in soils of low permeability. Leakage, even if small, as well as rain water, evaporation, condensation, *etc.*, can cause errors, which make the measuring results unreliable, even if the pore pressure is very stable.

The narrow open pipe in Case II can probably be used for measuring fairly constant pore pressure. It is not advisable to decrease the diameter any further because air bubbles might block the pipe.

The replacement of the open system in Case II by the closed system in Case III has a considerable influence on the measurement time lag.

It is probably significant for practical measurements that the changes in the volume factors are greater, and hence have a greater influence on the results, than the normal differences in filter area.

§ 1 c. Time Lag in Practice

In practice, the permissible time lags depend on the rate of change in pore pressure with the time.

Dynamic problems require extremely small volume factors (§ 1 b 2). None of the instruments discussed in what follows can be applied to such problems.

Rapid pore pressure changes in thick layers of low-permeability soils are generally caused by changes in external loads. In a large area this can be due to landslides, changes in water table above ground level, heaped stores, and also to rapid erection of buildings, *etc.* Locally, rapid pore pressure changes may be caused by pile-driving, sampling or field testing, drainage, excavations, *etc.*

In most of the above cases it is better to use a pore pressure meter having a very small volume factor (*e.g.*, that in Case III, § 1 b 2).

Slow pore pressure changes can be presumed to occur when large low-permeability soil masses consolidate under fairly constant conditions. For such problems, the meter used in Case II would do. It is however often economical to save time by quick measurements. Small time lags are also technically valuable for correct evaluation of the pore pressure changes. In practice, it is therefore always recommendable to use meters which have the smallest volume factors possible, without being too intricate or expensive¹. We think a volume factor of 0.3 to $1.0 \cdot 10^{-3}$ cm⁵/g is economical for a normal instrument, intended for use in low permeability soils.

In sand, where the permeability is high, more rapid changes in pore pressure may probably occur. Nevertheless, volume factors of the order of 10^{-2} cm⁵/g may be expected to be suitable for sand.

Instruments with a membrane which is pressed back to a zero position at the moment of measurement must cause great pore water flow and corresponding errors in measurements. In soils of low permeability such instruments should not be used. They are not included in this report.

§ 1 c 1. Filter Design

If the pipe is pushed down, the diameter of the filter should be a little smaller than that of the pipe.

Now two contradictory requirements concerning the pipe diameter have been stated in § 1 b. A small installation time lag requires a small diameter of pipe, and a small measurement time lag requires a great filter area, and hence, preferably, a great filter diameter.

Provided the meter has a small volume factor (§ 1 b 2), we may use a fairly small filter area, and the diameters of the pipe and the filter should therefore be reduced as much as is practically possible without jeopardizing the strength and the rigidity of the installation.

The optimum length of the filter depends on the type of problem. For instance, if we want to measure the pore pressure in a thin soil layer of high permeability, surrounded by a soil of low permeability, it is most probable that the permeable layer will be found by using a fairly long filter. The time lag calculations in this case must be based on a reduced filter area. In another case such a long filter may form an undesirable passage between two adjacent layers differing in pore pressure.

Although a long filter has the greatest filter area at a given diameter, a short filter affords more reliable information on the level of measurement, has a higher strength, and is easier to construct.

¹ Where stationary pore pressure can be predicted and only a few readings are required, one can use meters with measurement time lags as large as the installation time lag. Then instruments according to Case II will be economical. One must, however, be careful when assuming stationary conditions as ground water flow may exist even under rather level water surfaces.

§ 1 d. Special Considerations on Pore Pressure Meter Design

When studying available literature on pore pressure measurements, one is surprised by the great scarcity of data on the accuracy and sensitivity of measurements. This report contains some such data.

The error of the pore pressure meter (Δ_i g/cm²) can be given as a numerical value in metres of water column or in metric t/m². This establishes a simple relation with the soil problem, and the error can easily be calculated as a percentage of the depth of the meter point below ground level. The sensitivity of the meter, *i.e.* the smallest change in pore pressure that can be measured with certainty, is related to the error, and should preferably also be expressed in the same units.

According to § 1 b 1, the installation time lag seems to vary approximately as the square of the tube diameter. Therefore, the cross-sectional area (A_t , in cm²) of the tube near the meter point may be supposed to have an important influence on this lag.

From Eq. (11), § 1 b 2, we can obtain the factors which influence the measurement time lag. From the point of view of meter design, we have to consider only the volume factor, apart from the filter. The examples in § 1 b 2 showed that, for general design purposes, it is sufficient to know the order of magnitude of these factors.

The square root of the filter area can be represented by the "nominal filter diameter" $2 r_o$ (§ 1 b 2). This is the diameter of a sphere whose area is equal to the filter area.

Normal pore pressure meters must combine simplicity in operation with long-time stability. The use of electrical methods involving resistance, capacitance, inductance, or frequency can be deemed not to be desirable, since these methods are not simple enough to permit untrained persons living near an installed pore pressure meter to be charged with taking readings. In order to avoid great costs involved in sending qualified observers to far-off places, the meter must therefore be simple. The meters should not be touched during the measurements.

To prevent electrogalvanic currents and chemical action, all parts near the meter point should be made of the same metal or of noncorroding material.

§ 2. Early Hydraulic Meters of the Institute

§ 2 a. "Väsby" Meter

In the beginning of 1948, the Institute wanted to measure pore water pressure in connection with a large-scale field test concerning accelerated consolidation of clay. For this purpose, the meter shown in Fig. 2 was designed and constructed.

The principle of this meter is that pore water enters a chamber via a filter. The chamber is extended to the soil surface by a pipe provided with a pressure

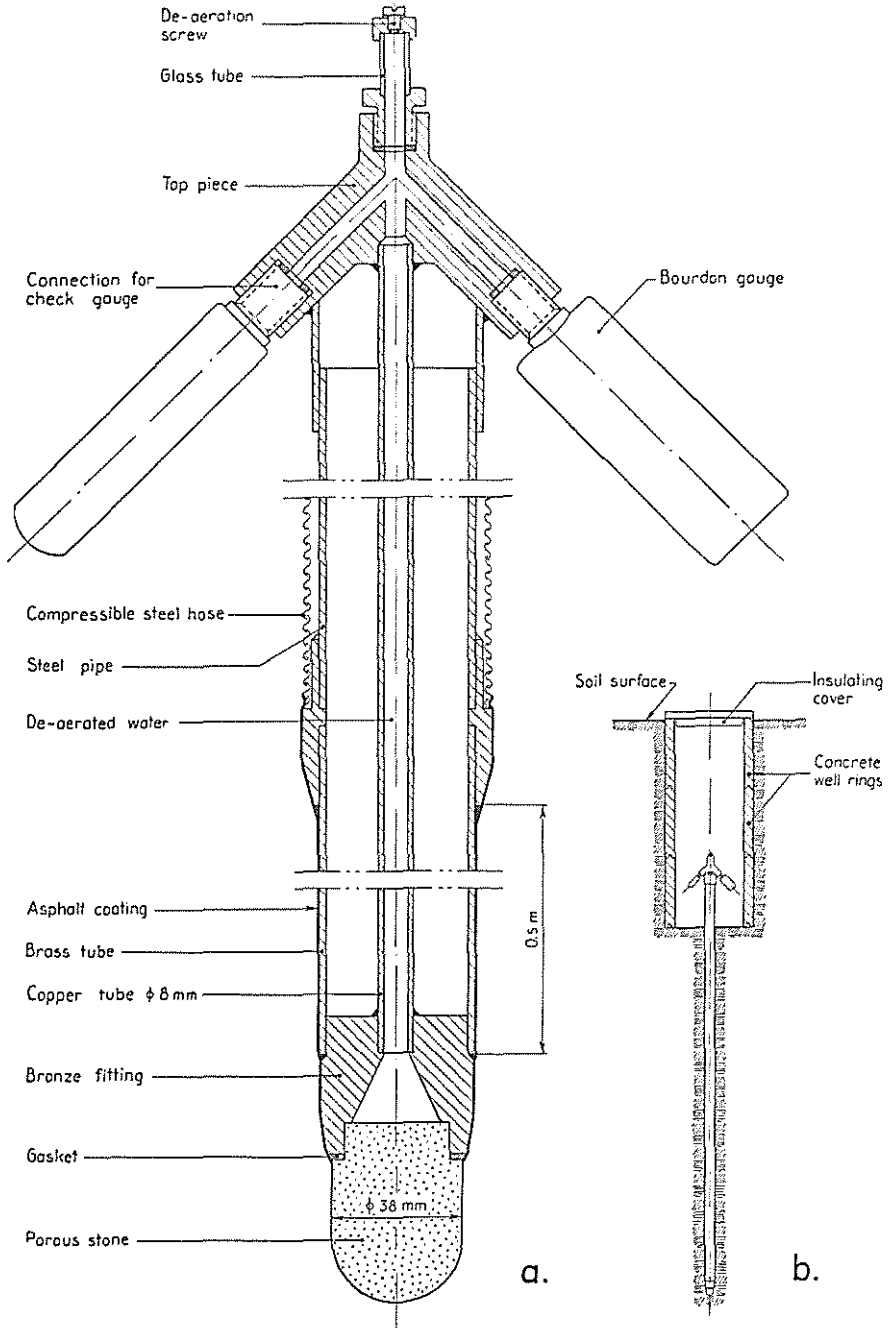

Fig. 2. Pore pressure meter, type "Väsby".
 a. Longitudinal section. b. Meter installed.

gauge at the top. This meter indicates the pore pressure minus the pressure of the water column between the filter and the pressure gauge.

The filter is a porous stone 38 mm in diameter mounted in a bronze fitting. This fitting is extended upwards by means of a copper tube, 8 mm in inside diameter, which ends in a top piece with a Bourdon gauge, a glass pipe with a de-aeration screw, and a reserve connection for a check gauge.

These parts form a system, the inner system, that is filled with water. Care is taken to permit gas bubbles to rise to the top, where they can be observed and expelled by adding water. The inner volume is made as small as possible to decrease the influence of thermal expansion of the water and to diminish the amount of bubbles formed when the pressure drops or the temperature rises. The inner system is protected by an outer system. The lowest part of the latter is a brass tube, 50 cm in length, extended upwards by means of a steel pipe with a compressible steel hose.

Shortly after the first field use, the external surfaces were coated with viscous asphalt. This was done in order to prevent the soil, which is settling during consolidation, from adhering to the pipe, since this would result in an extra load on the meter point and cause a subsequent pore water overpressure.

The meters were manufactured in single lengths without couplings, filled with de-aerated water, and checked in the factory. All joints were carefully sealed. During transport the filter stones were sealed with rubber coatings.

In order to avoid thermal influences, the upper parts of the meters were, after installation, enclosed in wells about 1.5 metres in depth below ground level, and were insulated by wooden covers.

Four meters were in use, and all gave results deemed to be reasonable, judging from calculation of stresses, from determination of settlements due to overload, and from testing shear strengths. The installation time lag was not specially studied.

The instrument data were as follows (*cf.* § 1 c)

Range:	— 4 to + 10 metres of water column
Estimated error:	± 10 cm of water column
Estimated sensitivity:	5 cm of water column
Cross-sectional area of tube (A_t):	15.8 cm ²
Nominal filter diameter ($2r_o$):	3.8 cm
Volume factor (θ):	$0.4 \cdot 10^{-4}$ cm ⁵ /g

§ 2 b. "Surte" Meter

The "Väsby" meter was developed in several steps towards greater handiness. The final meter of this type is shown in Fig. 3. It was first used in connection with investigations made after the landslide at Surte¹, and is therefore called the "Surte" meter.

¹ The site is described in Proc. No. 5 of the Institute.

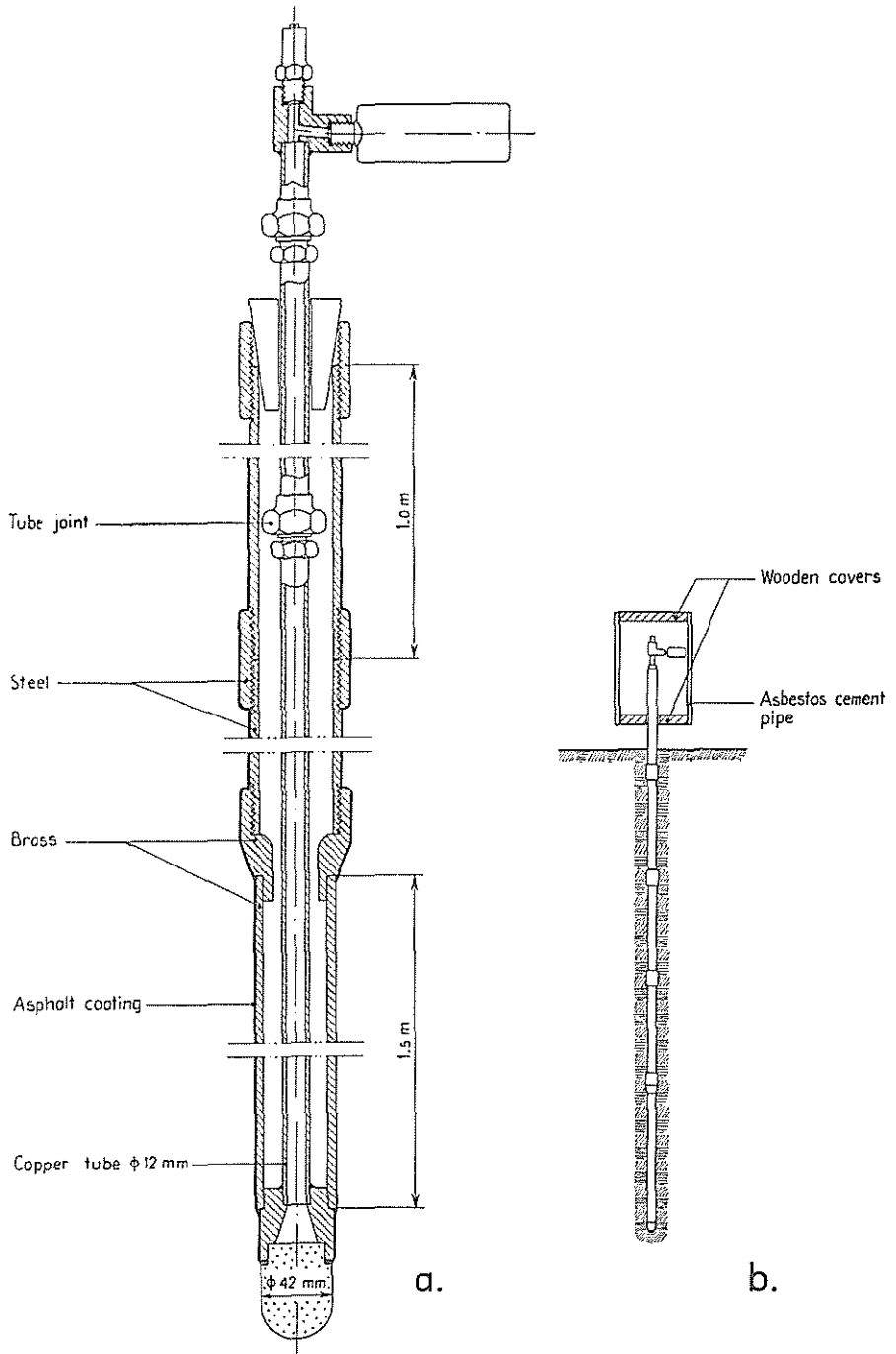

Fig. 3. Pore pressure meter, type "Surte".
 a. Longitudinal section. b. Meter installed.

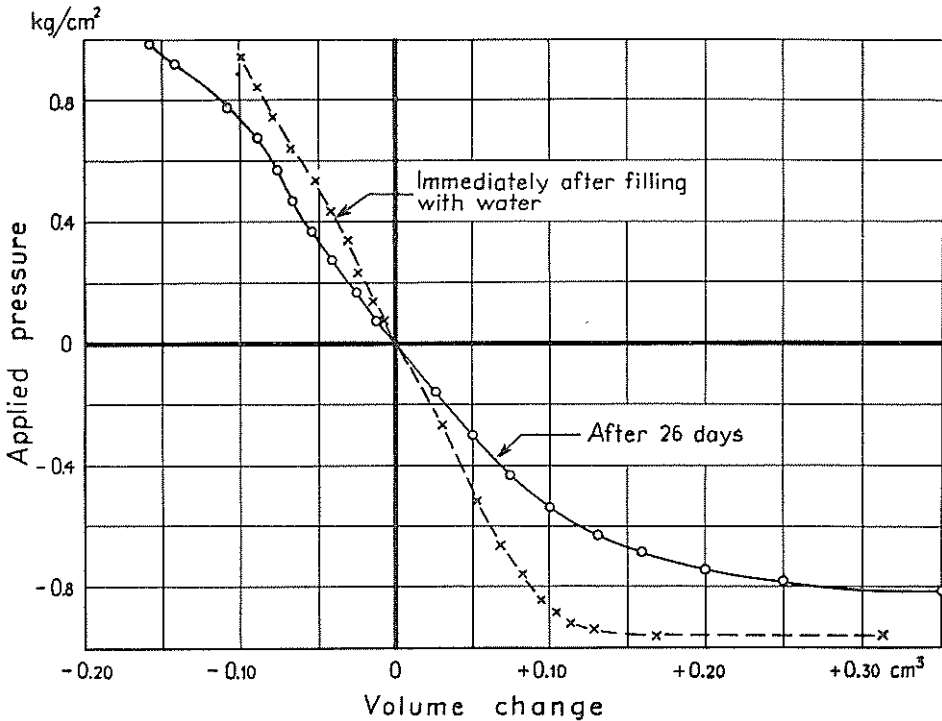

Fig. 4. Variation in volume with pressure in "Surte" meter with 3 m of tubing.

The inner and the outer pipes of the "Surte" meter were assembled in the field from pieces of convenient lengths. The meter was not surrounded by a flexible hose. The top piece was simplified as compared with that of the "Väsby" meter. Besides, the inner volume was increased.

The characteristic data of the "Surte" meter are almost the same as those of the "Väsby" meter. In reality, however, the measurement time lags of the "Surte" meter are probably greater owing to increased risk of gas bubble development in the system.

Fig. 4 shows the volume changes corresponding to different pressure readings in a meter with 3 metres of tubing calibrated in the laboratory. The dash-line curve shows the results of tests made immediately after filling with distilled water. The volume factor Θ (§ 1 b 2) on the pressure side is small, about 1×10^{-4} cm³/g. On the vacuum side, the volume change increases at a rate higher than the linear as the vacuum increases after a certain definite point (-0.6 kg/cm²). Below this point we must assume difficulties due to gas bubbles.

The full-line curve shows the results of testing the same device after 26 days' rest. On the vacuum side, the volume change tends to increase as the pressure decreases, which indicates that gases must have been present.

The main part of the water volume was contained in the 3 metres of tubing. If we had used longer tubing, the presence of gases would have involved a considerable risk of blocking by large bubbles.

On the pressure side, we also observe a similar but smaller influence of bubbles.

The "Surte" meter was in the beginning extended one metre above ground level.

As the meter was not protected against frost, its upper parts were filled with oil in the winter. Later on we found it desirable in this case, too, to enclose the upper parts in wells so as to decrease thermal influences.

The meter was normally pushed down by chain jacks. Hammering was avoided lest the joints of the inner system should loosen and leak. In spite of its considerable temperature sensitivity, this meter proved to be a suitable tool in many cases. However, it has now been replaced by the meters described further on in this report.

§ 2 c. Experience with First Hydraulic Meters

The "Väsby" meter was not read so systematically as to permit any special conclusions. Because of its similarity to the extensively used "Surte" meter, the experiences relating to this meter may be supposed to be applicable to both types of meters. Figs. 5 to 8 give some values observed with our "Surte" meter.

Figs. 5 a—e show typical examples of the pore pressure measurements made on a building site close to the site of the Surte landslide. The soil consisted of clay with sand layers. The clay had a permeability of about 10^{-8} cm/sec. Open pipes had been installed in the sand layers and pore pressure meters of the "Surte" type were used in the clay.

Fig. 5 d shows the results obtained from an installation in a fairly thick clay layer. The installation time lag seems to have been about six days (*cf.* also Figs. 7 and 8, which refer to similar conditions). In Fig. 5 a the installation time lags are smaller owing to a higher average permeability of the soil.

During hot, sunny days followed by cold nights the temperature influence was sometimes annoyingly great (± 0.1 kg/cm²). In such cases the readings had to be taken frequently during 24 hours, and diagrams representing pore pressure readings versus temperature had to be plotted.

Fig. 6 shows the pore pressure measurements in a clay fill for a road embankment. Here two "Surte" meters had been installed at small depths. The air temperature was measured at the same time as the pore pressure. We see that the meter situated at a depth of 2.5 m was dependent on the temperature. It

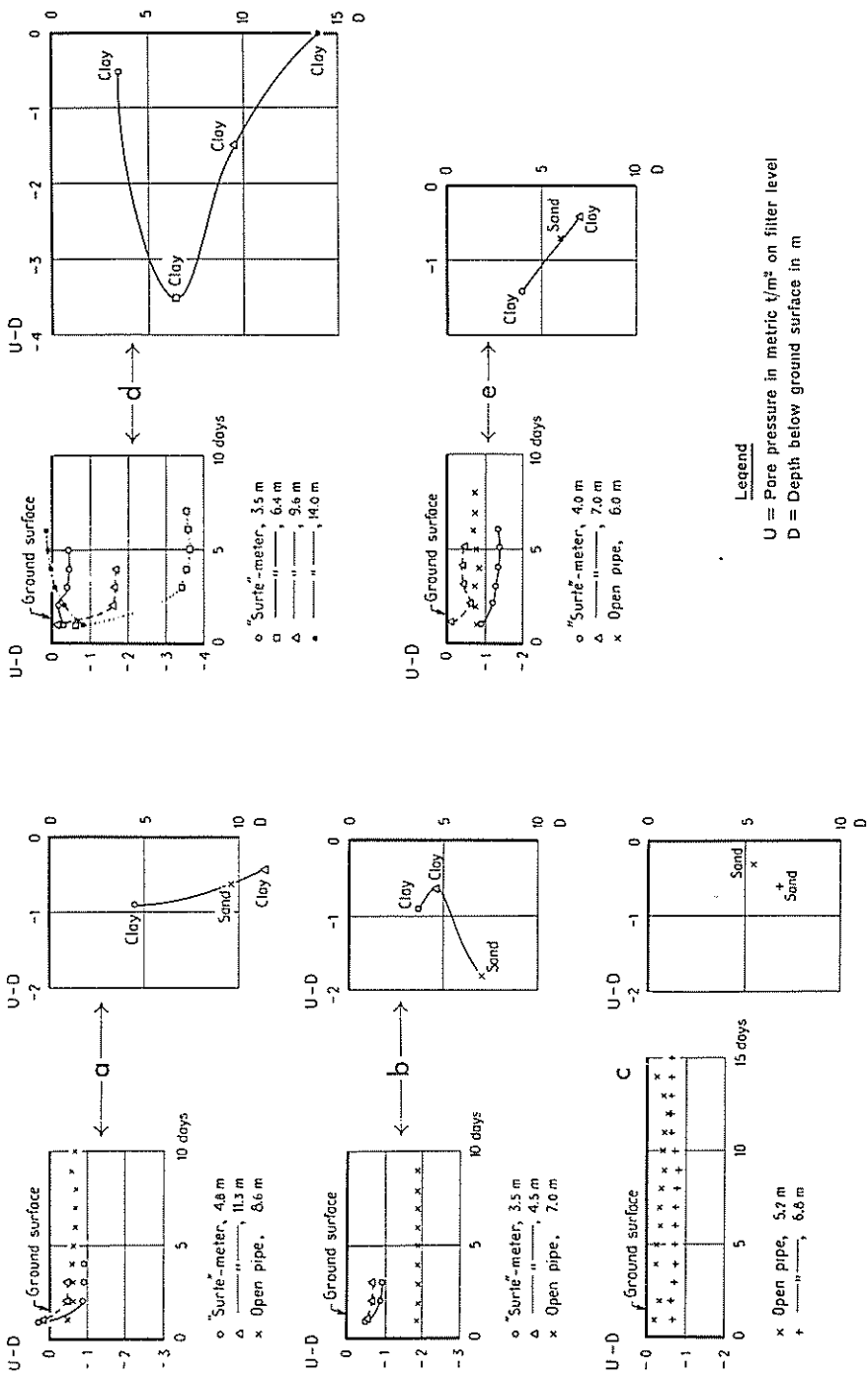

Fig. 5. Pore pressure measurements on a building site at Surte (November to December, 1950).

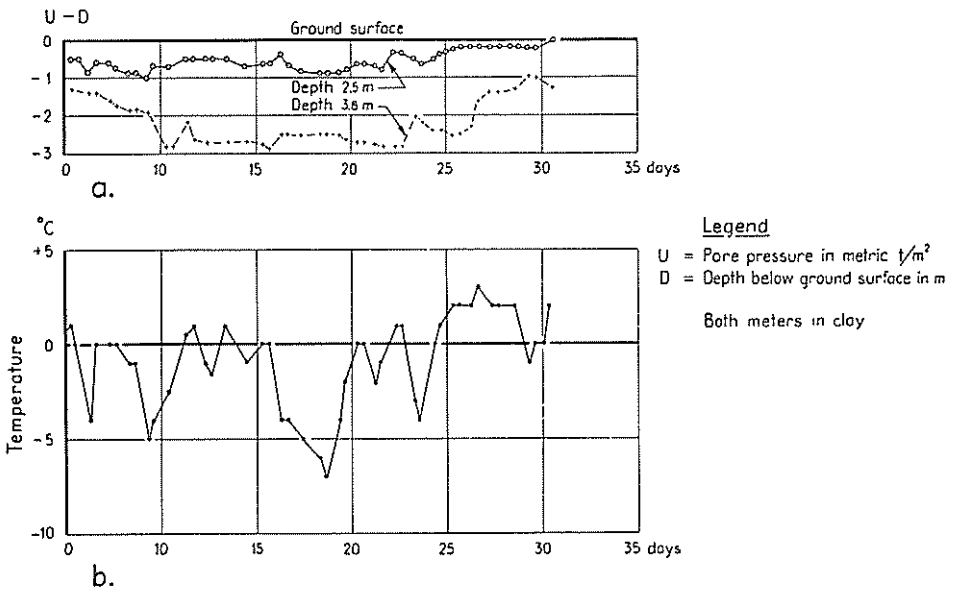

Fig. 6. Measurements with "Surte" meter in an embankment on National Main Road No. 6, Finlösa—Högen, in southwestern Sweden (December, 1953, to January, 1954).

- a. Pore pressure measurements.
- b. Air temperature measurements.

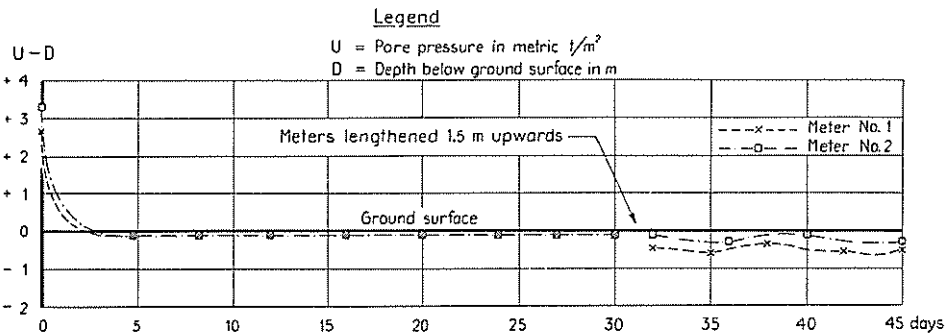

Fig. 7. Tests to demonstrate the value of thermal insulation (two "Surte" meters in clay at Enköping).

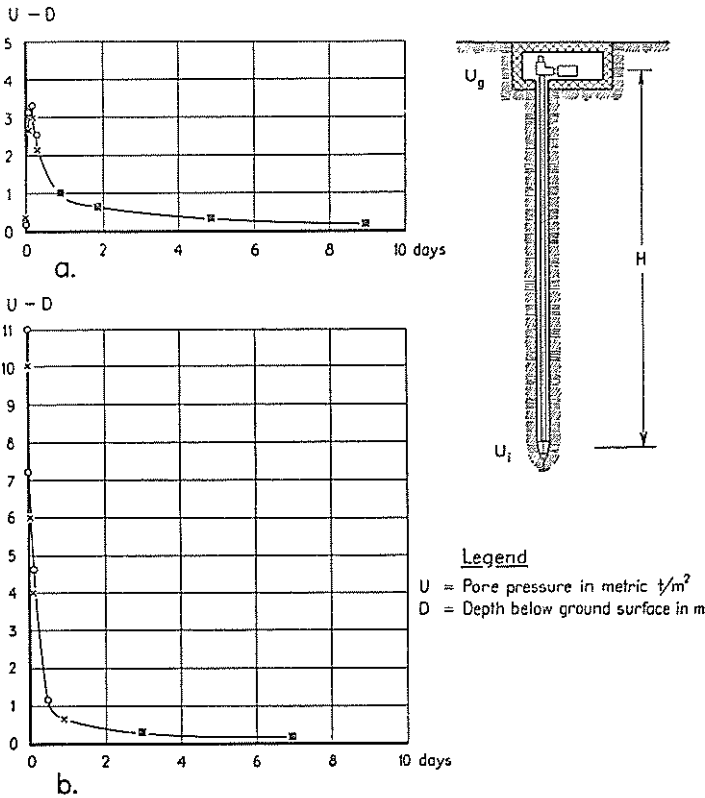

Fig. 8. Pore pressure measurements with four "Surte" meters in clay at Lilla Mällösa (9 to 29 December, 1954).

- a. Two meters filled with water after installation.
 b. Two meters filled before installation and kept under an internal overpressure of 1 kg/cm^2 during installation.

seems that the meter situated at a depth of 3.8 m might also have been temperature-sensitive, but this was delayed about two days.

An experiment to demonstrate the value of thermal insulation is shown in Fig. 7. Here the measurements were made in clay at a depth of 6 m. Two "Surte" meters had first been installed with the gauges in a shallow pit. The measurements showed an installation time lag of about five days and then almost constant values during about 25 days. After that both meters were extended upwards 1.5 m, without any other change. The gauge was now situated above the ground surface. Then the measurements began to vary in a similar way as those in Fig. 6. This indicates that the thermal insulation of the meter is very important.

Fig. 8 shows the results relating to four "Surte" meters installed in clay (permeability 10^{-8} cm/sec) about 40 km north of Stockholm. All these meters

had their filters at a depth of about 5 m. Two meters were installed in a normal way (Fig. 8 a), while the two other meters were kept for special reasons at an internal overpressure of 1 kg/cm² during installation. The installation time lag was about a week in both cases. The curves seem to be fairly smooth.

The measurements indicate that closed hydraulic meters should and can successfully be insulated so as to protect them against temperature changes. Insulation has therefore been the standard practice at the Institute during the past few years.

§ 3. First Electro Pneumatic Meter of the Institute

If the ground water table (static height of pore pressure) lies below the pressure gauge, then pressures below the atmospheric will arise in the inner system of a water-filled pore pressure meter. Even at a difference in level of about 3 to 5 m, troubles due to gas bubbles in the water begin to be serious when using the meters described in § 2. At a difference of 6 to 7 m, the measurements are practically impossible (cf. Fig. 4)¹.

To enable measurements of very low ground water tables, our first electro pneumatic meter was designed and constructed.

§ 3 a. Principles

The measuring system is shown in principle in Fig. 9.

The pore water, passing through the filter stone, exerts a direct pressure on a membrane, the lower membrane, which is deflected upwards. Above this there is an upper membrane, which can be deflected downwards by compressed air. Each membrane is provided with an electrical contact.

By means of the contacts attached to the two membranes it is possible to determine the air pressure required to deflect the upper membrane so much that its contact just touches the contact of the lower membrane. The more the latter is deflected by the pore pressure, the less the upper membrane needs to be deflected. The air pressure is regulated and read on the soil surface.

The electrical system consists of a dry cell, a milliammeter, and an electrical resistance, all connected in series in a circuit including the contacts on the membranes. The circuit can be short-circuited for checking by means of a push-button switch.

The measurements are made by slowly increasing the air pressure above the upper membrane until the milliammeter indicates that contact has only just been established in the pick-up. This procedure can be repeated in order to ensure reliable measurements.

¹ One can, of course, increase the range a little by using measuring systems where water can be circulated to remove air bubbles. We believe it to be difficult to avoid pressure disturbances when handling such systems in low permeability soils.

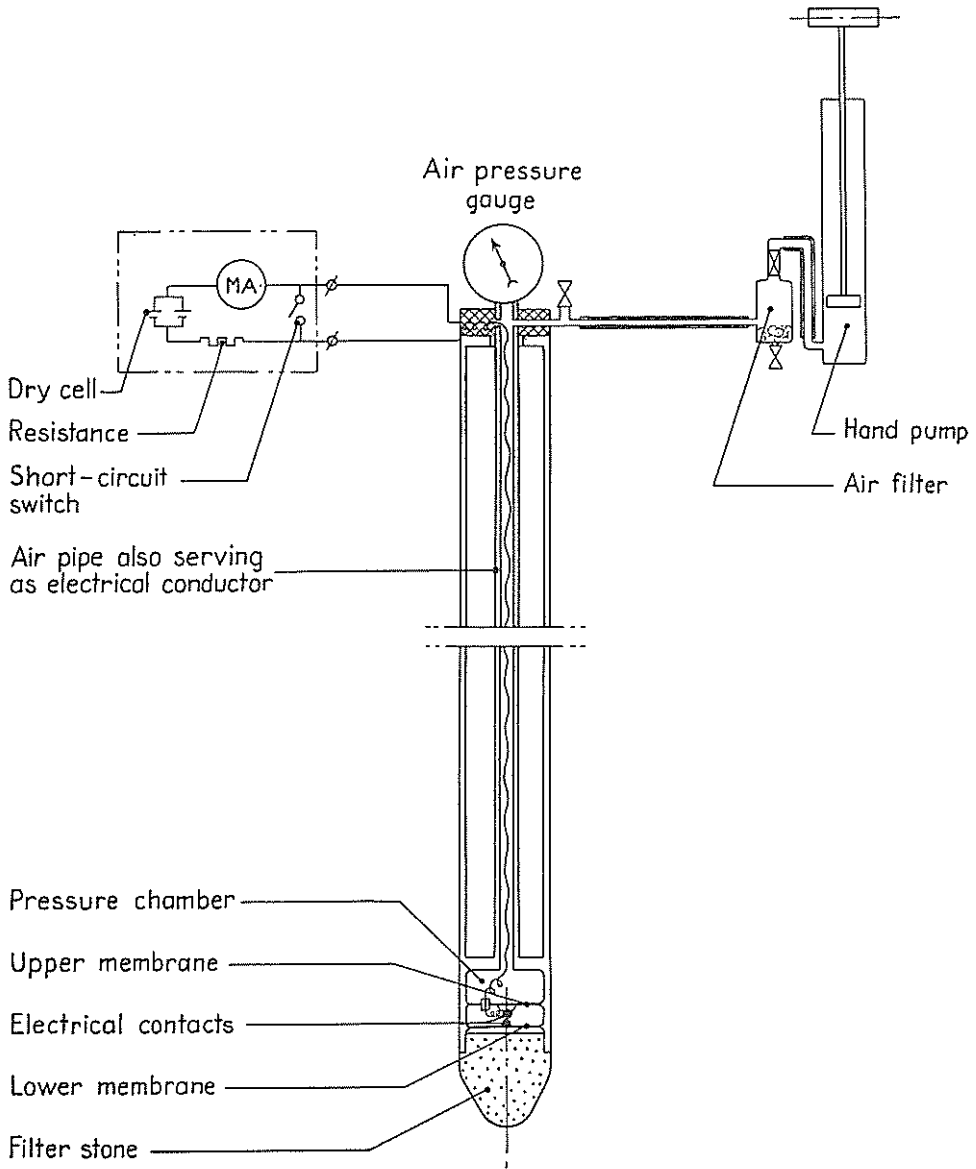

Fig. 9. Principle of the first electro pneumatic meter.

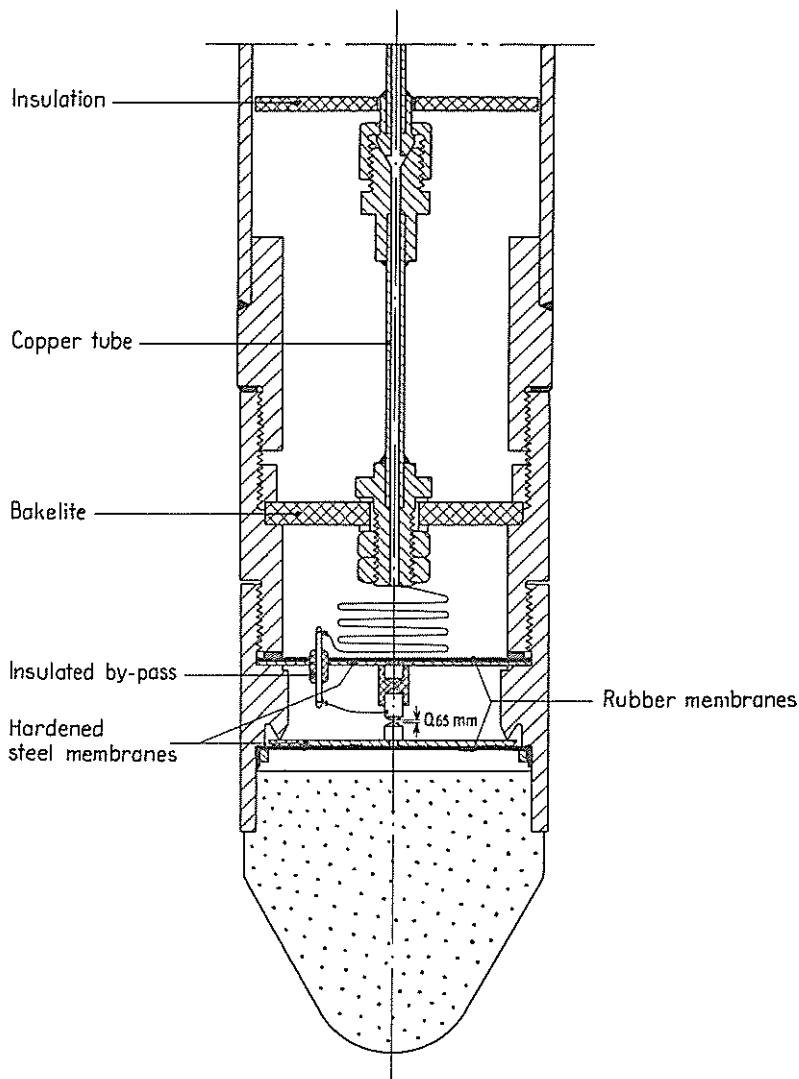

Fig. 10. First electro pneumatic pick-up. Longitudinal section.

§ 3 b. Design and Use

The electro pneumatic pick-up is shown in Fig. 10. The membranes consist of thin hardened steel plates resting on ring-shaped surfaces. Thin rubber membranes act as gaskets. The total deflection of each membrane is 0.65 mm.

The contacts are made of platinum, and are carefully tested. Fig. 11 shows one of several tests indicating the accuracy in determination of travel by means of these contacts. We obtained an accuracy in measurements of about ± 0.001

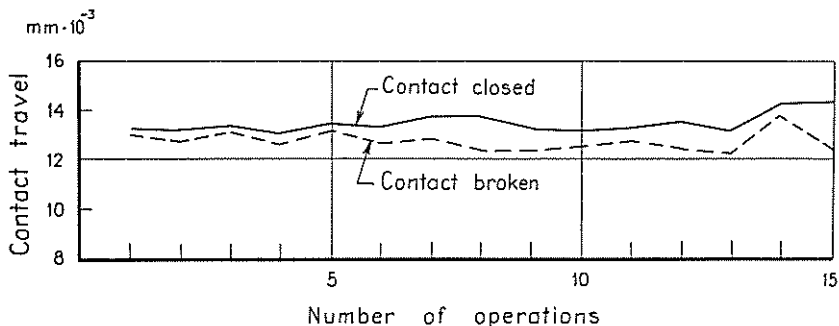

Fig. 11. Accuracy of contacts.

mm, regardless of whether the contacts worked in air or in oil. This is equal to about 0.2% of the deflection range of the membranes and may be expected to be satisfactory in most cases.

Originally, the air was supplied by an ordinary hand-pump with a filter for drying and cleaning the air. The air pressure is read on a Bourdon gauge. The air is fed to the pressure chamber through copper tubing, which also serves as an electrical conductor connecting the dry cell to the upper contact. The pipe is electrically insulated by means of plates spaced 1.5 m apart. The lower contact is connected to the protection pipe which serves as a return conductor leading to the dry cell.

The details of the meter are seen in Fig. 12.

To deal with a special problem, one meter was made with a wide range extending from 0 to 95 metres of water column. The calibration curve of this meter is shown in Fig. 13. This meter was slightly temperature-sensitive because of the air volume enclosed between the two membranes. This was deemed not to be serious as the pick-up would be situated at levels where the soil temperature is nearly constant.

The instrument data are:

Range:	0 — 95 m of water column
Error:	± 1 m of water column (mainly due to the pressure gauge)
Sensitivity:	20 cm of water column (mainly due to the contact)
Cross-sectional area of tube (A_t):	19.6 cm ²
Nominal filter diameter ($2r_o$):	3.8 cm
Volume factor (θ):	$0.4 \cdot 10^{-4}$ cm ⁵ /g

The meter was used in an investigation at Mo i Rana, Norway. The operator made a number of measurements without troubles, but had once to hammer the meter down with a few blows. On account of this, and maybe also owing to excess pore pressure, the contacts were slightly damaged. Therefore, it

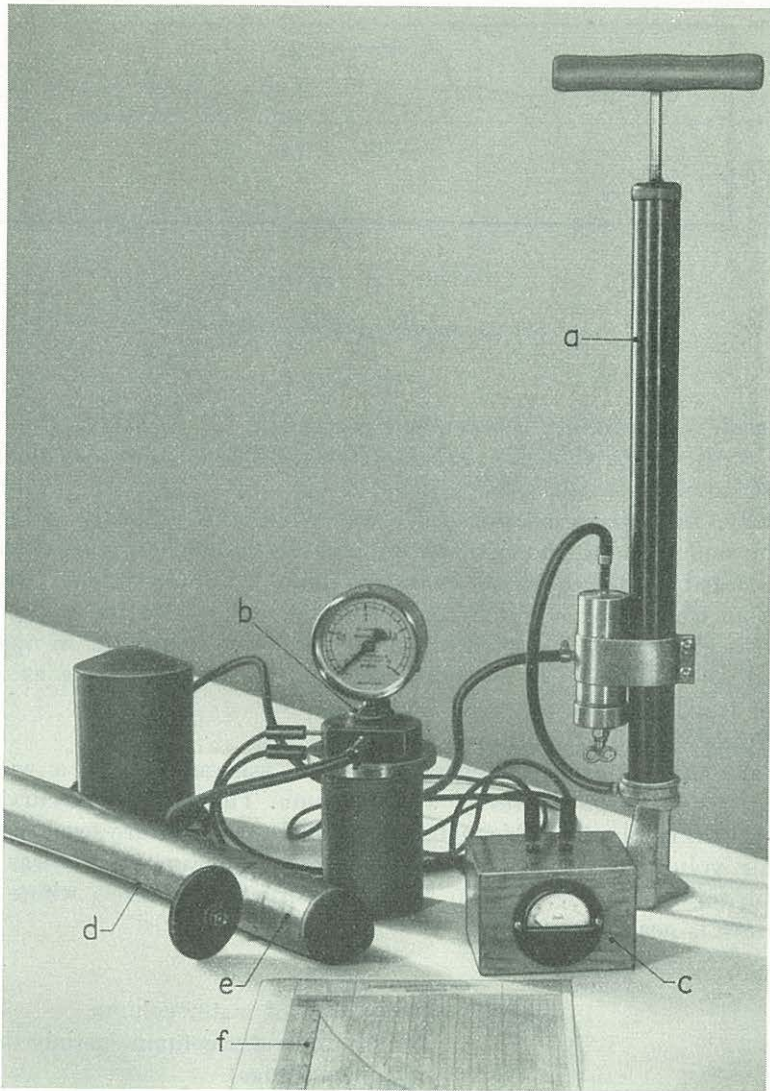

Fig. 12. Details of the first electro pneumatic meter.

- a. Hand pump with air filter.
- b. Top piece with Bourdon gauge.
- c. Contact checking device.
- d. Conductor with insulation.
- e. Pick-up with filter stone.
- f. Calibration diagram.

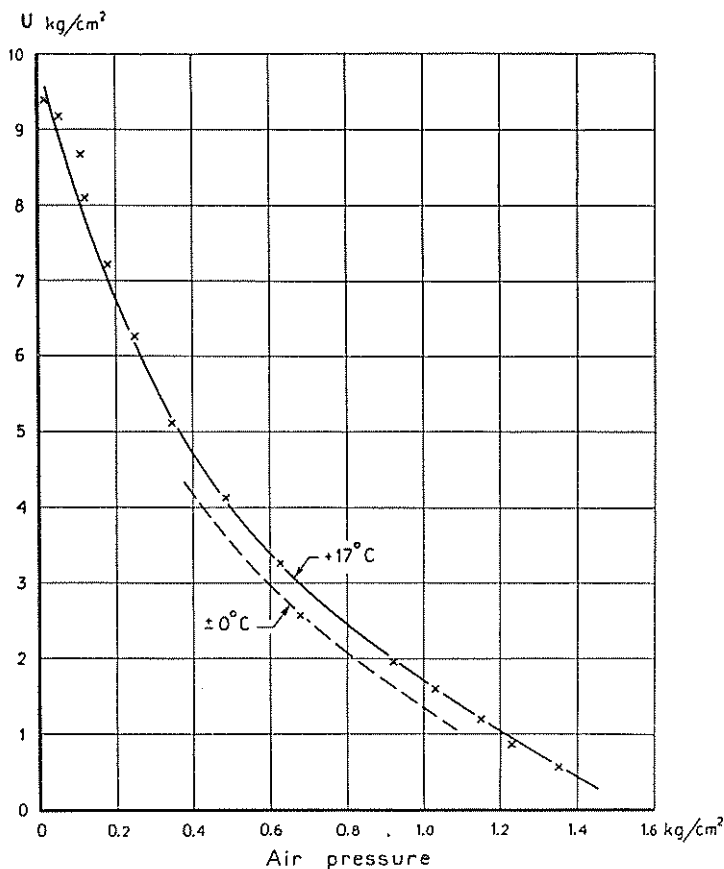

Fig. 13. Calibration curve of the first electro pneumatic meter.

became necessary to use a special protection pipe (Fig. 14) with a filter stone. This pipe was first driven into the soil. Afterwards the meter with its pipe was inserted in the protection pipe until close contact was established between two conical surfaces. This worked but was not convenient.

The pressure pick-up was reliable during short-time tests, but its calibration curve showed a tendency to change during long-time measurements. This was found to be due to the fact that the air from the space between the membranes diffused through the rubber membranes.

The first electro pneumatic meter was soon discarded as the Institute developed a new system of pore pressure measurements, which is described in the following section.

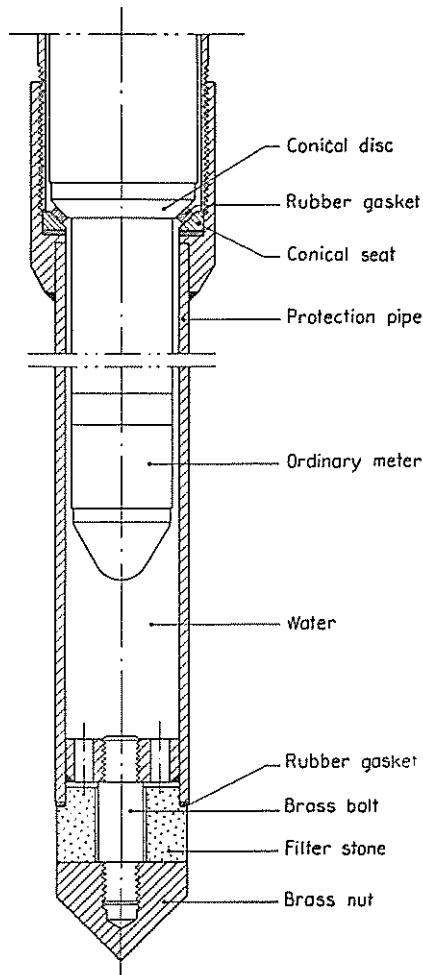

Fig. 14. First electro pneumatic meter. Protection pipe.

§ 4. SGI Pore Pressure Measuring System

§ 4 a. Principles

In September 1950, it was conceived that a connection, which could be used for pore pressure meters to join in situ the pipe with the filter to the measuring element (situated as close to the filter as possible), would give several advantages.

On the basis of such a connection between the filter pipe and the instrument, the Institute has since developed a pore pressure measuring system—here called

the SGI system—which can be flexibly adapted to most field investigation requirements.

The main advantages of this system are:

a) The filter tube can be installed without the instrument. Therefore, the risk of damaging the instrument by dynamic forces or excess pore pressure at the meter point during installation will be eliminated.

b) At any desired moment the measuring instrument (“pick-up”) can be calibrated or checked, simply by disconnecting it from the filter and holding it in the water-filled tube at different levels.

c) A defective instrument can be easily replaced. This will ensure long life of each pipe installation.

d) Great accuracy can be obtained by first making a rough pore pressure determination and then replacing the simple wide-range instrument by a narrow-range precision meter.

e) In non-saturated soils where gases might cause trouble in the filter a “bulb” of saturated soil can be achieved close to the filter by first connecting a hose containing water under slight overpressure to the filter, after a while replacing this hose with a pore pressure meter.

The system consists of parts which can be combined in different ways. For instance, we have the filter pipe with different filter points. We have also several kinds of pick-ups, *e.g.*, oil-filled or electro pneumatic pick-ups for ordinary cases (described in what follows) and a special precision pick-up (§ 5).

The connection between the filter and the pick-up is standardized and will be described first (§ 4 b) in order to facilitate understanding the details of the system.

There are cases where the SGI system connection cannot be used, *e.g.*, in such embankments, where the connection tube must be installed more or less horizontally. Here we can use the pick-ups, in the first place the oil-filled hydraulic pick-ups, with the filter directly connected. This is possible since the manufacturing costs of the parts which will remain in the soil are comparatively low.

§ 4 b. Instrument Connection

The SGI connection between the filter and pick-up is shown in Fig. 15. It consists of two parts, the nozzle, which forms part of the filter pipe system, and the lower part of the pick-up.

The pick-up having a hole drilled to fit on the nozzle is sunk down in the pipe. It is guided onto the nozzle by conical surfaces until a ring-shaped rubber gasket in the pick-up rests tightly against a ring-shaped contact surface at the top of the nozzle. The dead weight of the pick-up is about 1.4 kg, and the contact area is about 0.1 cm², so that the specific contact pressure is 14 kg/cm². This is sufficient for all normal needs, especially as the cross-sectional area of the hole in the nozzle is only 0.07 cm². Pore water flow past the rubber gasket is ensured by a small pipe inset at the centre of the gasket.

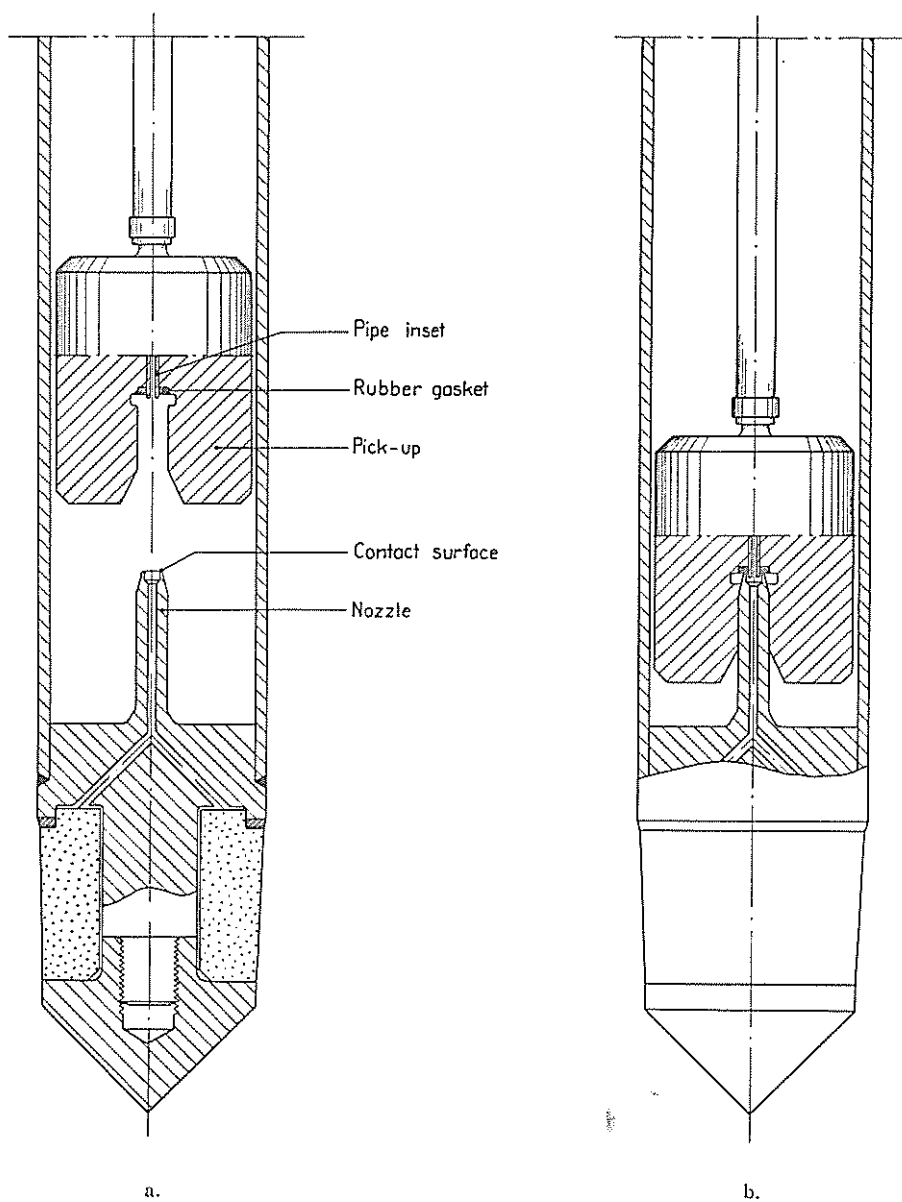

Fig. 15. SGI instrument connection.

- a. Before connecting.
- b. Connected.

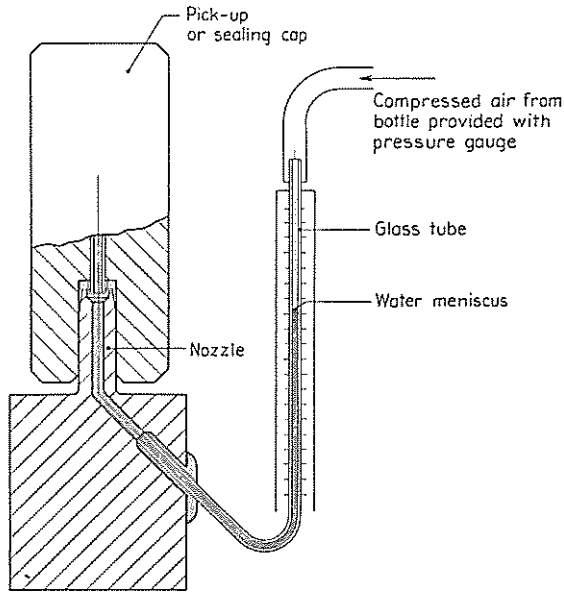

Fig. 16. Device for checking volume factor and tightness of connection.

The tightness of this connection was tested in the laboratory. For this purpose, a test device was made, see Fig. 16. The air pressure was kept constant at 4 kg/cm^2 on a water meniscus in a glass tube. This tube was connected to a nozzle covered with a sealing cap which was similar in weight, shape, and dimensions to a pick-up. The connection proved so tight that no leakage was observed even after the pressure had been applied for a period of six days. By replacing the sealing cap by a pick-up, the volume factor of the latter can be determined.

Five years' practical experience with the connection has shown that it is reliable. Trouble has arisen in a few cases, when dirt came into the pipe, and when inexperienced personnel did not check the tightness. On one occasion, the pick-up was so cold that the water inside the connection froze and blocked the channel.

Air bubbles can be entrapped in the connection. The remedy is to fill the hole in the pick-up completely with water by means of a syringe. When inserting the pick-up in the filter pipe, it is convenient to have the whole pipe filled with water. Then a check can be made at ground level to make sure that no air bubbles are present. If it is not possible to fill the pipe sufficiently, the bottom hole of the pick-up can be covered with a piece of plastic tape after filling the hole. The nozzle will penetrate the tape, and the connection will be free from air bubbles. When using hydraulic pick-ups, a proof of the tightness of the connection is that the interior pressure quickly rises a little just when the connection is made.

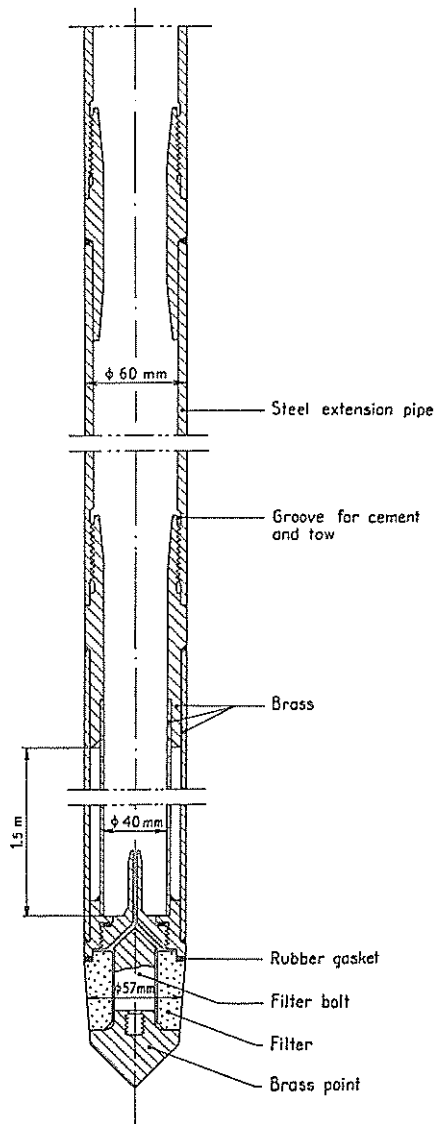

Fig. 17. Filter pipe, type SGI I.

§ 4 c. Filter Pipe

§ 4 c 1. Design

The filter pipe hitherto used in practice is shown in Fig. 17.

The maximum outer diameter (§ 1 c) is 6 cm. This diameter permits the use of inside couplings, leaving sufficient passage for a pick-up of not too small

dimensions. The filter is at the lower end. It is made of sintered carborundum. It has a slightly conical shape, the diameter increasing from 5.6 cm at the bottom to 5.8 cm at the top. The effective height is 4.0 cm, which corresponds to a filter area of 72 cm² and a nominal filter diameter (§ 1 b 2) of 4.8 cm.

The filter is mounted on a brass bolt and protected by a brass point serving as a nut. The movement of this point is confined by a ring-shaped surface. Furthermore as the filter stone rests on a thick rubber gasket the stone is not subjected to any great forces during installation. Therefore, we have not had any trouble due to damaged filters. The upper end of the bolt forms the nozzle, described in § 4 b. These parts can be disjoined from the rest of the pipe in order to facilitate cleaning of the pipe, if needed.

The lowest part of the pipe proper is double-walled, and is made of brass. The outer tube forms part of the extension pipe. The inner tube has a slightly smaller inner diameter than the couplings, and serves to guide the pick-up onto the nozzle. The double-walled part is welded, at the bottom end to a fitting holding the filter bolt, and at the upper end to a special coupling.

Above this coupling there are extension pipes made of steel (0.5% C) with welded inside couplings. These pipes are fairly long to reduce the number of joints, thus decreasing the risk of soil leakage into the pipe through the joints. The extension pipes have a wall thickness of 0.5 cm.

Fig. 18 shows that we have reduced the diameter in our latest design from 6 cm to 4.8 cm, without any drawbacks. In this way, the installation time lag is reduced from about 8—12 days to 5—7 days in a clay, having a permeability of 10⁻⁸ cm/sec, as the cross-sectional area has been reduced from 28.4 cm² to 18.2 cm² (§ 1 b 1), which has been ascertained by experience.

As can also be seen from Fig. 18, we have now two different filter types. The normal filter is 10 cm long and has an area of 140 cm² (nominal filter diameter 6.7 cm). The other is 50 cm long, and is intended for measuring pore pressures in thin sand layers.

§ 4 c 2. Filter Pipe in Practice

Normally, a hole, about 20 cm in diameter and 60 cm in depth, is first bored on the spot where an installation is to be made. This hole is then filled with water. The bottom end of the filter pipe is inserted in the hole, and is kept in water until the water in the hole has thoroughly penetrated the filter, and has reached almost the same level in the tube and in the hole. In this way, all air entrapped in the filter and the nozzle is expelled upwards. To prevent dirt from entering the interior, all pipe joints are carefully sealed with pipe joint cement and tow in the grooves made specially for this purpose.

In the measurements made by the Institute, the pipe is normally pressed down by means of jacks or, preferably, by a winch mounted on a truck with power take-off. In hard soil or at great depths we also use hammering.

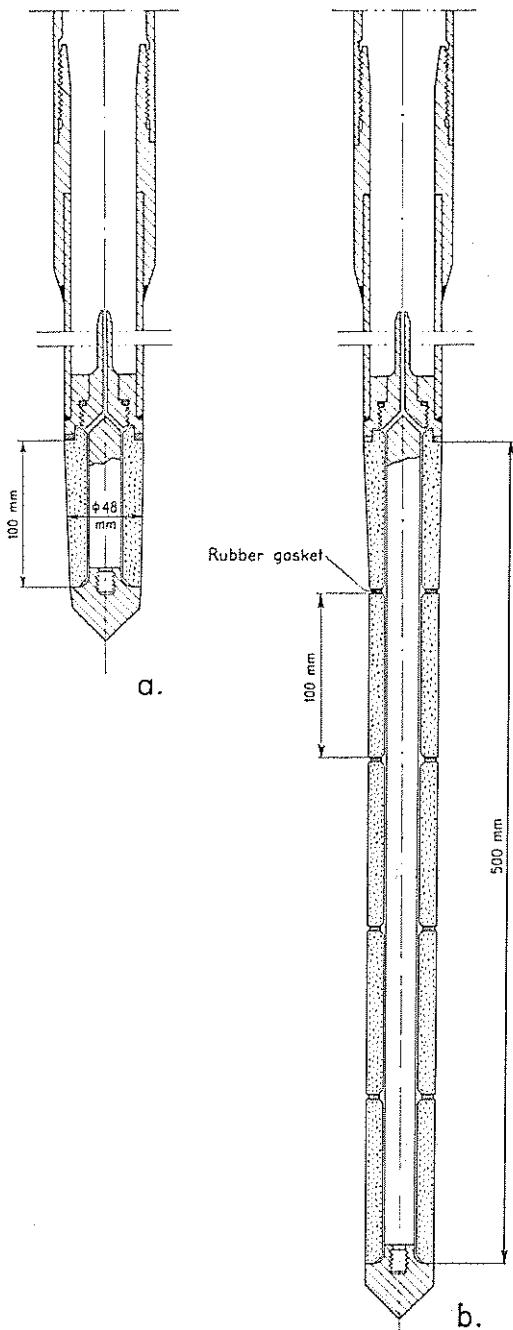

Fig. 18. Filter pipe, type SGI II.
 a. Filter of normal length.
 b. Lengthened filter for thin sand layers.

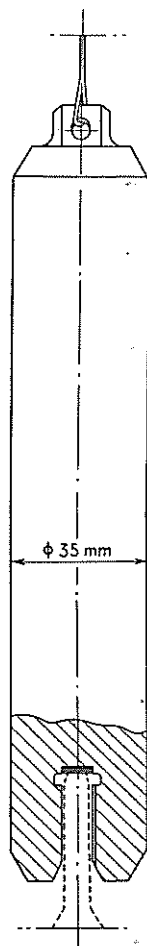

Fig. 19. Sealing cap.

After installation the pipe is filled entirely with water unless the pore pressure is supposed to be very low. In the latter case water is only filled to a level corresponding to the assumed free pore water table.

In low-permeability soils the pipe is left open about one day to permit the initial great pore water overpressure to be reduced below an acceptable limit. Then either the pick-up or the sealing cap shown in Fig. 19 is connected to the nozzle. This is done to prevent the natural pore pressure from being changed by the water pressure in the pipe.

It is necessary to avoid freezing of the pick-up during winter days.

In non-saturated soils it is advisable to let water seep from the filter pipe into the soil closest to the filter a sufficient time to form a "bulb" of saturated soil around the filter point. In this way one avoids troubles from gases entering the filter from the outside.

§ 4 d. Oil-Filled Pick-Up

§ 4 d 1. Principles

The system with oil-filled pick-up is a further development of the early hydraulic meters described in § 2. In principle the pore pressure in this system is also transmitted from the meter point through a fluid in a pipe to a Bourdon gauge situated at ground level. The essential difference is that the pressure transmission system is entirely filled with silicon oil, and forms a closed unit, which is assembled in the workshop. The lowest part of this unit is provided with an extremely flexible thin rubber diaphragm, which separates the fluid in this system from the pore water but can transmit the pore pressure with a very small pressure loss. By using the oil fill, we are to a very great extent free from troubles due to gas bubbles. We can therefore radically decrease the diameter of the connecting pipe to a capillary size. The tube can then easily be wound around a drum, and can be handled like a rope.

A further advantage of the oil fill is that the measuring system is frost-proof. It also permits measurements of ground-water tables which are slightly deeper than in the case of the water fill, owing to the smaller specific gravity and vapour pressure of the oil and to the absence of gas bubbles. The freedom from gases gives the additional advantage that the fluid is almost incompressible at the pressures under consideration. Consequently, the measurement time lags are very small. On the other hand, we obtain time lags if the oil is too viscous, since the resistance to flow in the capillary tube will then be high. Thin silicon oil has a low viscosity even at low temperatures, and we have therefore eliminated this source of error.

The specific gravity of the oil must be exactly known for determining the pore pressure which corresponds to a given gauge reading. We refer to Fig. 8 and the following symbols,

- γ = specific gravity of oil, in kg/cm³
- u_g = pressure indicated by gauge, in metres of water column
- H = vertical distance, in metres, from gauge to half the height of the filter
- u_i = pore water pressure in filter, in metres of water column.

We then have

$$u_i = H\gamma + u_g \dots \dots \dots (12)$$

§ 4 d 2. Design and Construction

The oil-filled pick-up is shown in Fig. 20.

The rubber membrane is very thin, and has an approximately semispherical shape. It is provided with a rim at the circumference. The lower part of the pick-up is extended by means of a thin piece of tube.

When assembling the pick-up, the lower part and the upper part can be pressed together, and the tube of the lower part can be soldered to the upper part. The position of this solder joint at a sufficient distance from the rubber membrane prevents the soldering heat from destroying the membrane.

The connection between the element body and the Bourdon gauge is a copper capillary 3 mm in outer diameter and only 1.5 mm in inner diameter. It is welded to standard type pipe fittings. The length of our capillary tube is normally 20 or 30 metres.

First we tried plastic tubing, which has been used in some countries. We found, however, that a great amount of gas bubbles appeared in this tubing as soon as it was in contact with air. Therefore we made some tests. We cut polyethylene and polyvinylchloride tubing into one-metre lengths, which were filled with water. After closing the ends, the test pieces were kept in the laboratory and weighed each day. Already after one day air bubbles were observed in the polyvinylchloride tubes, and after about ten days these tubes were empty. Also the polyethylene tubing showed considerable, although less, permeability. Similar tests with viscous oil showed no tendency of the oil to disappear. These tests induced us to avoid plastic tubing in our pore pressure meter designs. (Later tests with Saran tubing showed, however, that this material is satisfactory.)

The Bourdon gauge is all-bronze.

Before assembling the system, each part is first separately filled with evacuated oil. To put the diaphragm in a neutral position, the pick-up is placed on a calibration nozzle (*cf.* Fig. 16). A syringe is used to remove 3 cm³ of oil from the upper chamber, at the same time as air is let in through the nozzle until the oil level in the upper chamber again reaches its original position. As the Bourdon gauge will only require about 0.2 cm³ of oil to move through the whole range, we know that the diaphragm will never reach its ultimate positions, provided that the system is tight.

Fig. 21 shows the assembled system. Fig. 22 shows the calibrated volume change of the instrument (*cf.* Fig. 4).

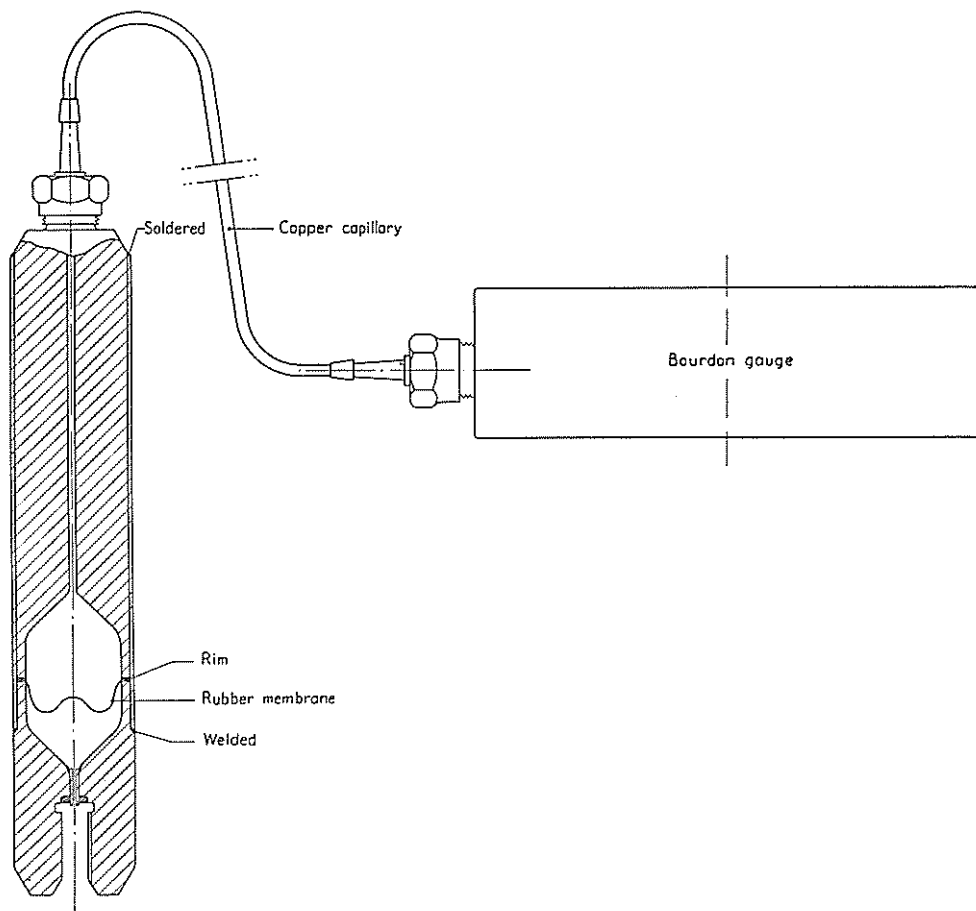

Fig. 20. Oil-filled pick-up. Longitudinal section.

The data of this instrument are as follows:

Range: — 10 to + 10 m of water column

Error: ± 10 cm of water column

Sensitivity: 5 cm of water column

Volume factor (Θ): $2 \cdot 10^{-4}$ cm⁵/g

A comparison with the meters described in § 2 shows that the accuracy and the sensitivity of this instrument are theoretically the same as those of the "Väsby" meter. In practice, however, the new instrument is much more reliable, as disturbances due to gas bubbles are avoided almost entirely, and calibration is possible under field conditions. The measurement time lag is much smaller owing, partly to a greater nominal filter diameter and partly to a smaller real volume factor.

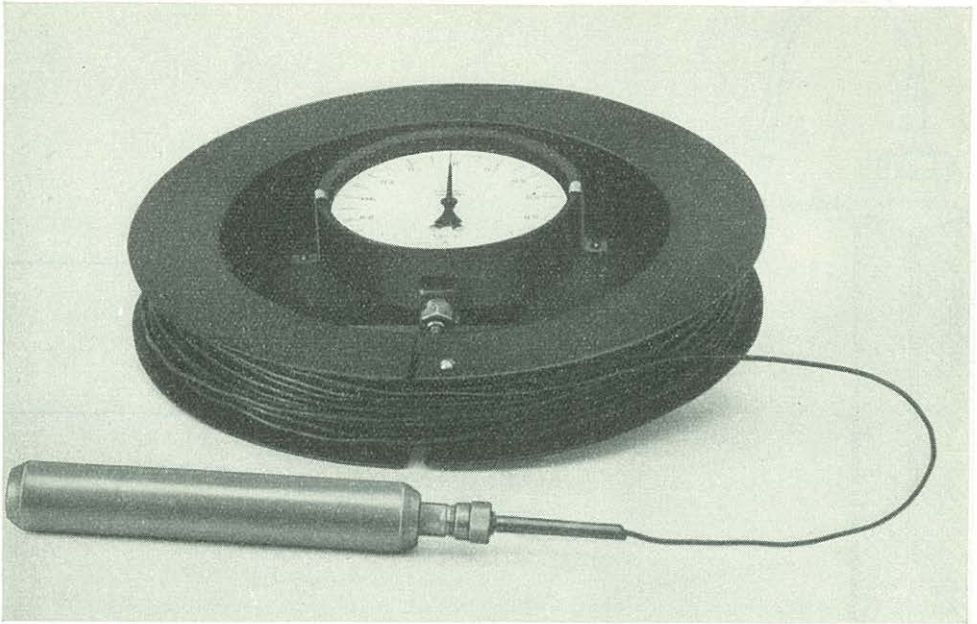

Fig. 21. Oil-filled pick-up.

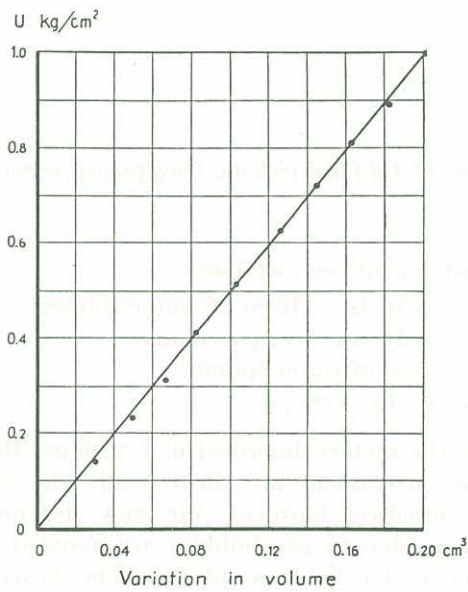

Fig. 22. Oil-filled pick-up. Variation in volume with pressure.

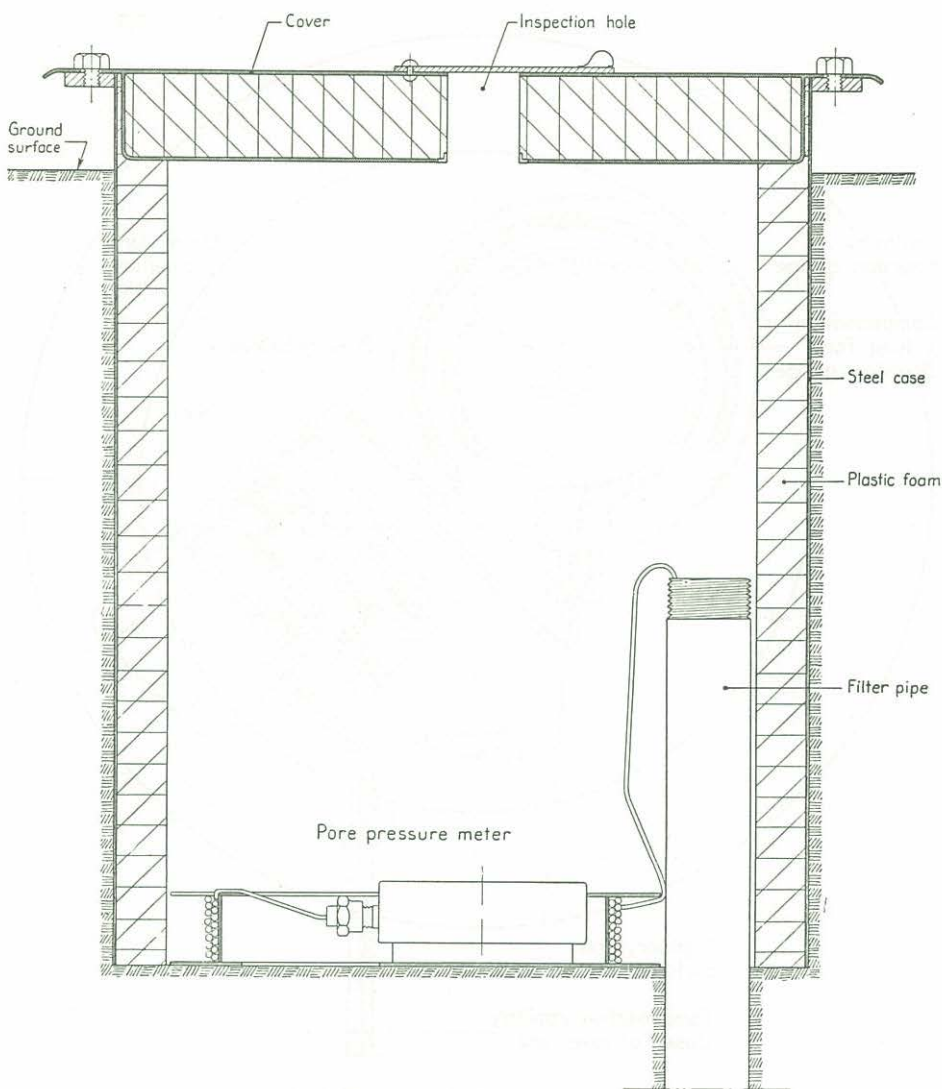

Fig. 23. Insulating box.

A point of special importance is the temperature sensitivity shown in § 2. Liquid-filled closed systems are temperature-sensitive, and special measures must be taken to counteract this. A simple calculation shows the great importance of thermal influences. Our Bourdon gauge has an inner volume of $19\,000\text{ mm}^3$ and requires a volume change of 200 mm^3 to indicate a pore pressure change of ten metres of water column. Now the coefficient of thermal expansion of the oil is 0.0009 . If the temperature changes 10° C , which, at sun-

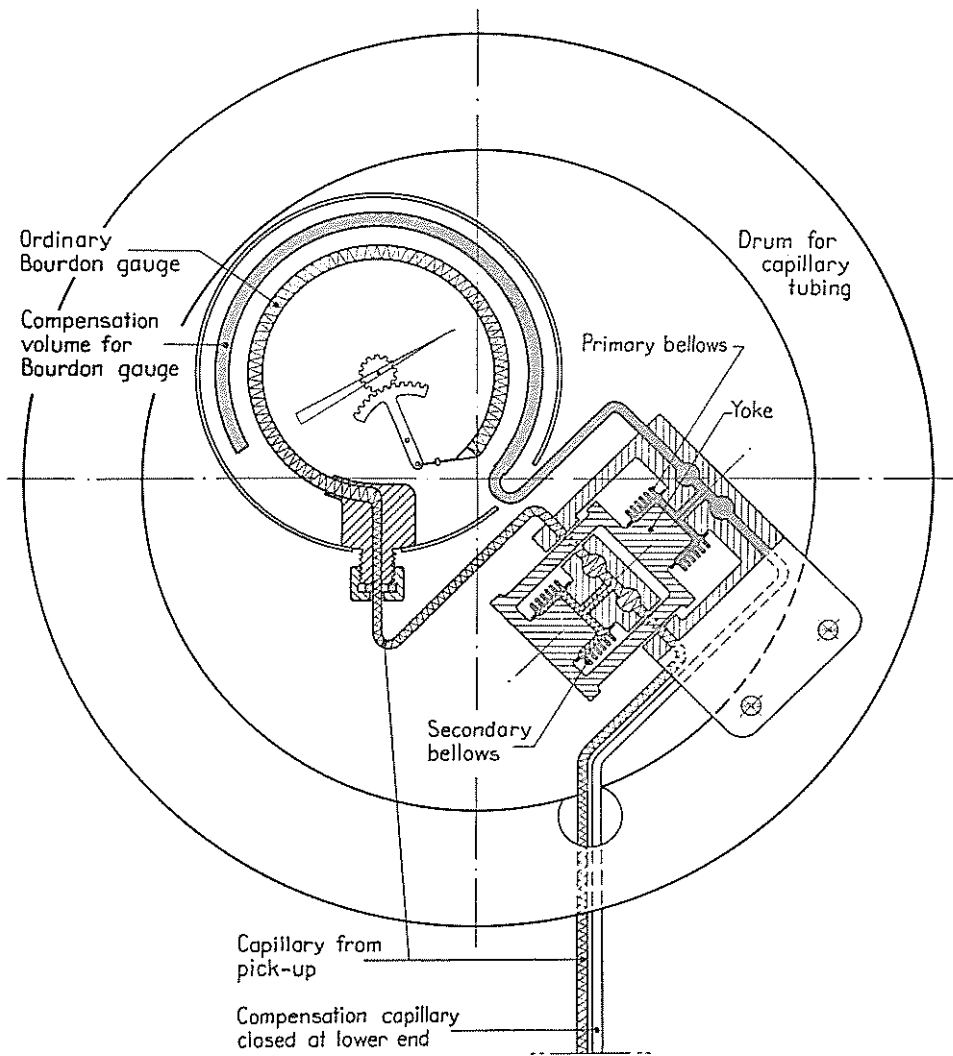

Fig. 24. Temperature-compensating device for oil-filled pore pressure meter.

rise, can take few hours, then the volume change in the manometer is $10 \cdot 0.0009 \cdot 19\,000 = 170 \text{ mm}^3$. Thus, the volume change can extend almost through the whole range of the manometer.

The volume changes in the capillary tube are small in comparison with those in the manometer, and amount to only about 18 mm^3 per metre of length per 10° C of temperature change. If the system were filled with water, which has a coefficient of thermal expansion of only 0.00018 , the influence of the manometer

would be smaller but, on the other hand, the influence of the wider connecting tube which would then be required would be greater. If the Bourdon gauge is enclosed in an insulating box placed in the soil, see Fig. 23, then the soil has an equalizing effect on the temperature. Our experience has shown that the thermal influences are small in such installations, provided the observer does not open the cover when taking a reading. The insulating box serves also as a protection against damage.

However, there are cases where it is impossible to insulate the gauge sufficiently. Such a case is discussed in § 4 g (Fig. 35). Then the measuring system can be provided with a temperature-compensating device, see Fig. 24. The principle of this device is stated in what follows.

A fluid is enclosed in a temperature-compensating system. This system is arranged so that it is subjected to the same temperature changes as the measuring system. When the compensating fluid changes in volume owing to temperature variations, it deflects a primary bellows. This bellows acts on a secondary bellows situated in the measuring system, thus compensating the latter for volume changes caused by temperature. This device, which is in reality small and rugged, has been tested a few months and has hitherto worked well.

If the filter pipe has been installed for a sufficiently long time, each reading can be taken in about half an hour after the pick-up has been connected.

As regards the measuring costs, it is to be noted that the most expensive part of most systems is the filter-pipe and not the pick-up. However, the quick response of the pick-up saves time, and makes the meter therefore comparatively cheap in use.

§ 4 e. Electro Pneumatic Pick-Up

The electro pneumatic pick-up is used for the same purposes as the first electro pneumatic meter (§ 3). Thus, it is primarily intended for low ground-water levels.

§ 4 e 1. Principles

The principles of this pick-up are the same as those of the meter described in § 3. However, the present pick-up is far ahead of the first meter which has been developed in several stages in order to prevent some noticed disturbances. The disturbances were due to frictional forces at the periphery of the membranes, to electrical short-circuits caused by moisture, to insufficient electrical contacts, to the air pressure arising between the membranes, and to air diffusion through the rubber covers of the membranes. All these disturbances have been almost completely eliminated in the latest design, and the reliability has been considerably increased.

The membranes have been replaced by bronze bellows (Fig. 25). They can be soldered to their fittings, and can thus be made quite tight. They are smaller in diameter than the membranes, and the volume change corresponding to a given displacement has therefore been reduced.

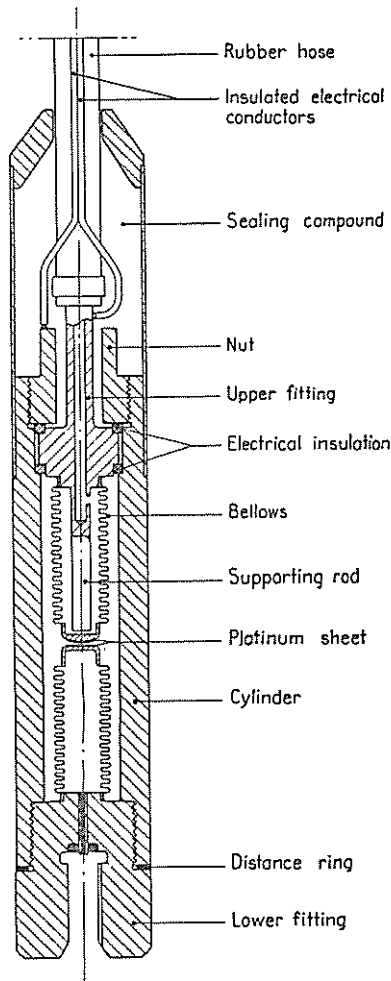

Fig. 25. Electro pneumatic pick-up. Longitudinal section.

The measuring principle permits fairly high precision, but the main purpose is to ensure ruggedness. We get an instrument accuracy of ± 10 cm of water column and a sensitivity of 2 cm, which is mainly determined by the Bourdon gauge.

§ 4 e 2. Design and Construction

Fig. 25 shows the pick-up.

A fitting at the lower end seals the nozzle. A bellows is hard-soldered to the top of this fitting. The lower fitting is screwed in a brass cylinder. A distance ring between these two parts ensures the exact position of the lower bellows in relation to the upper.

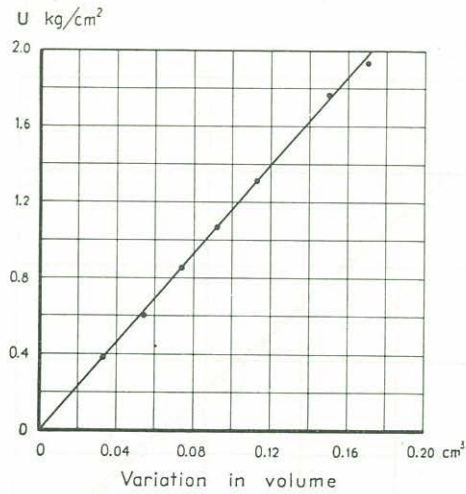

Fig. 26. Electro pneumatic pick-up. Variation in volume with pressure.

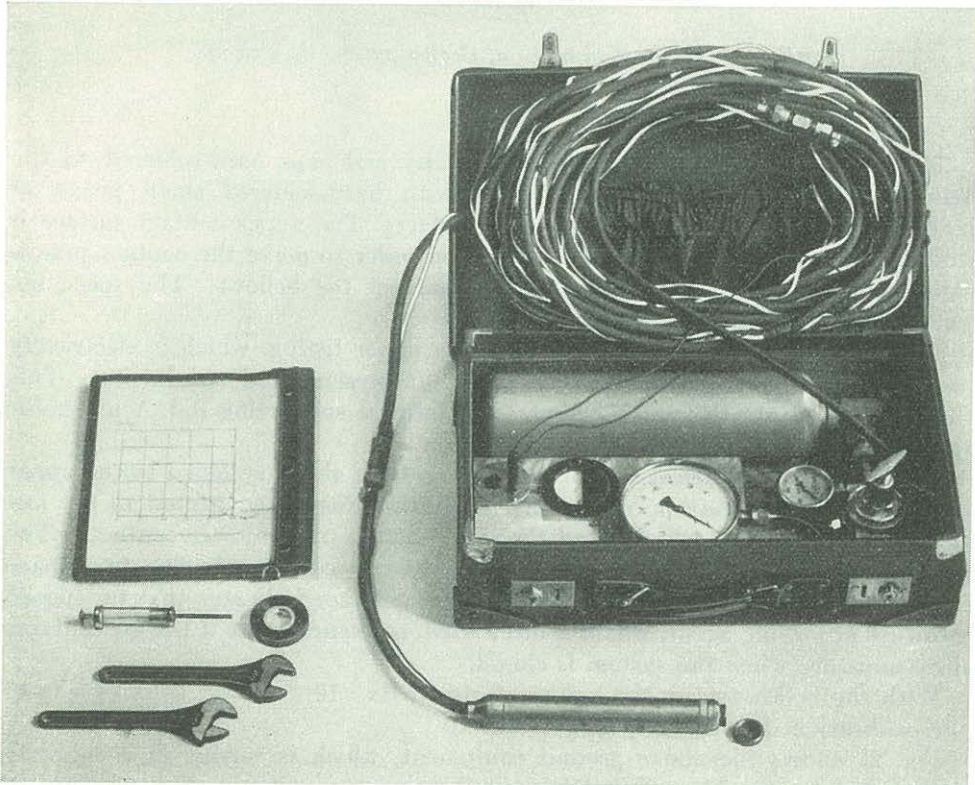

Fig. 27. Electro pneumatic meter. Measuring outfit.

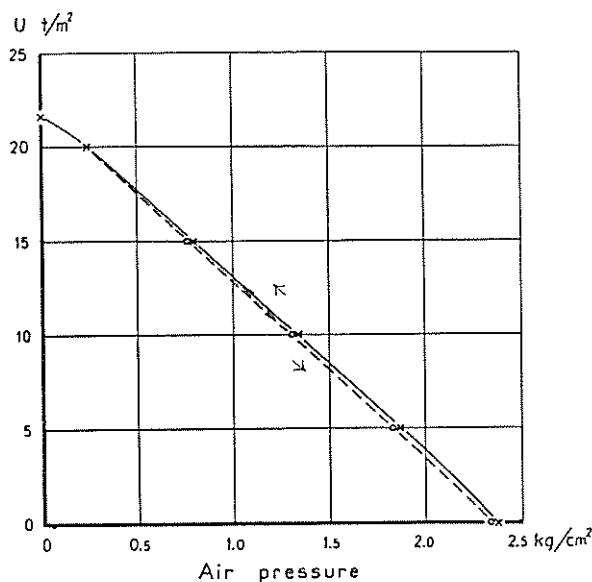

Fig. 28. Calibration curve of electro pneumatic pick-up.

The free ends of the bellows are closed by end caps hard-soldered to the bellows. These caps are also provided with hard-soldered small pieces of platinum sheet, which form the contact surfaces. The upper contact surface is slightly curved, and the lower one is plane in order to make the contact practically independent of small lateral movements of the bellows. The space between the two contacts is 2.5 mm at zero pressure.

The upper bellows is hard-soldered to the upper fitting, which is electrically insulated from the cylinder by two rings (at present made of Lucite). This fitting extends into the upper bellows, and forms a supporting rod. A nut holds the fitting in a fixed position.

One of the two electrical conductors coming from above is joined to the upper fitting (leading to the upper contact), while the other is connected to the nut (leading through the cylinder and the lower fitting to the lower contact). The top of the measuring insert is filled with sealing compound. The free space inside the cylinder is air-filled. So far, our experience indicates that no special moisture-absorbing agent, which is often used, is required here if the air contains little moisture when the system is closed.

With the bellows used, the volume factor is $0.9 \cdot 10^{-4} \text{ cm}^5/\text{g}$, as is seen from the calibration diagram in Fig. 26.

Fig. 27 shows the above ground equipment, which is carried in a specially designed suitcase. The air bottle contains five litres of air at a pressure of 150 kg/cm². This pressure is read on the small manometer, which indicates how

much air is still available. The larger manometer measures the air pressure after the air has passed the reducing valve (which is seen on the right). On the left of the larger manometer there is a milliammeter, which indicates when the circuit is closed. Further to the left there is a push button for checking the dry cells.

Outside the suitcase we see the pick-up with its connecting hose and electrical conductors, a calibration diagram, the wrenches for connecting the hose, the syringe for filling the pick-up hole with water, and the plastic tape for occasional use (§ 4 b).

Fig. 28 shows a calibration diagram of the latest meter.

§ 4 f. Recording Instruments

From Eq. (10 a) (§ 1 b 2) we see that a correct evaluation of the pore pressure in the soil from instrument readings requires several readings taken at sufficiently small intervals of time, to obtain the time derivative of the instrument readings. It is useful to obtain the maxima and minima of the instrument readings because Eq. (10) shows that no measurement time lag is present at these values. From this point of view, it is advisable to have written records.

The oil-filled pick-up can easily be combined with a recording instrument.

For a special investigation, the Institute wanted to have records covering at least one year. The recording instruments designed for this purpose are briefly described in what follows.

§ 4 f 1. Ink Recorder

The simplest way to construct a recording pore pressure meter is to use a standard pressure recorder and to connect its pressure gauge to the oil-filled pick-up. In view of its small friction and simplicity an ink recorder is suitable in this case.

A drawback of the ink recorder is that the minimum paper speed must be about 0.5 mm per hour to make the ink flow smoothly. One year's measurements will therefore require a diagram over 4 m in length, which is fairly great. The length can be reduced by reading the diagram at certain intervals and by redrawing it on a smaller time scale.

The Institute has two recorders which are spring-driven, and must be rewound once a month. These instruments have been in use about a year, and we have had very little trouble with them so far.

§ 4 f 2. Optical Recorders

In order to enable long-time recording without obtaining too long diagrams and with a minimum of friction, the Institute designed and constructed meters for optical recording on photographic film.

The original idea was very simple, and is shown in Fig. 29. A mirror is fastened on a standard Bourdon gauge. Daylight enters through a tube with

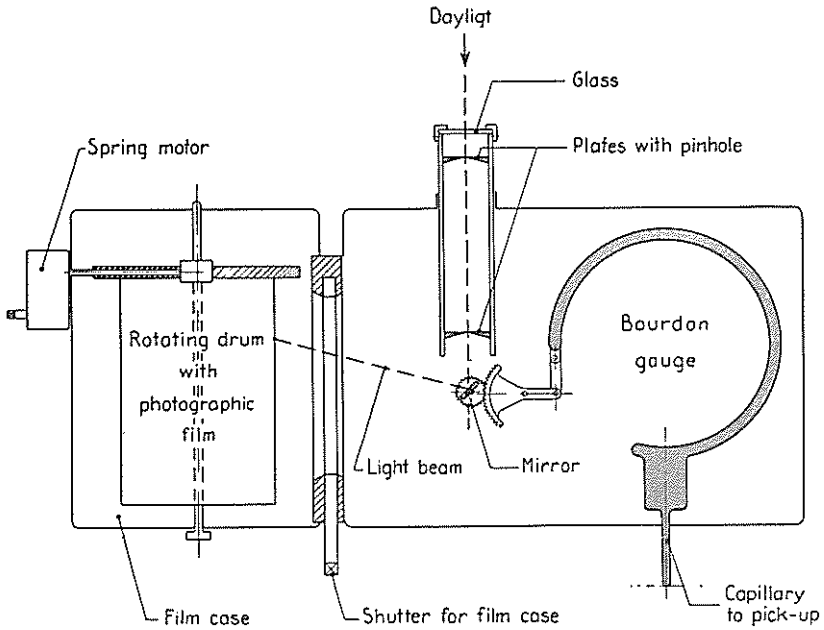

Fig. 29. Simple optical recorder.

two pinholes, 0.2 mm in diameter, forming a spot of light that is reflected by the mirror on to a film on a rotating drum. This drum makes in our case one turn per year, and is driven by a spring. Exposure tests showed that it is possible to obtain good records throughout the year, even in very faint daylight. This idea has not yet been realized because we were afraid that snow in the winter might interrupt the record.

Therefore we made an optical recorder using artificial light (Fig. 30)¹. The only difference from Fig. 29 is the optical system.

The light source consists of two miniature electrical bulbs, which are fed with current impulses of only 1/10 sec duration. The bulbs are lit alternatively, so that a flash is produced every second hour if both bulbs are intact. Should one bulb be defective, one flash would anyway be obtained every fourth hour. The light from the bulbs is concentrated and focused on the photographic film, after being reflected by the movable mirror.

The electrical current is supplied from an accumulator, and is primarily fed to an electrical clock, wound up ten times an hour by the stroke of an electromagnet. It is the current flowing through this electromagnet that is utilized for the flashes. A disc fastened on the hour hand of the clock switches

¹ Devised in co-operation with Mr Werner Bergau, Mechanical Department, of the Institute.

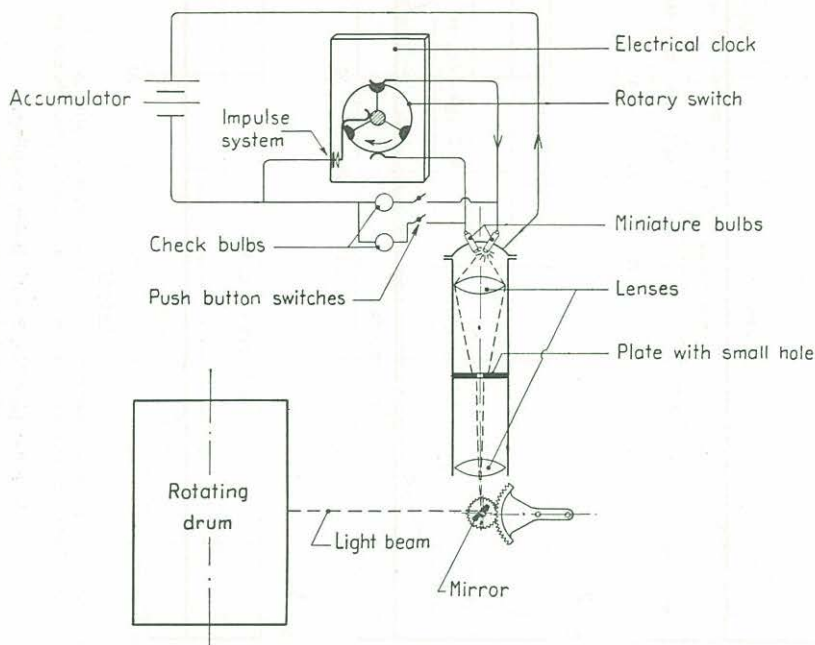

Fig. 30. Artificial light system for optical recorder.

on the bulbs alternatively during a time that is sufficiently long to enable one flash impulse to be fed through the bulb each time it is switched on. In one year, the effective time of current flow through a bulb is only one hour. This ensures long life of bulbs and current supply. The accumulators should easily last a year.

The bulbs can be checked by means of check bulbs. During this, the bulbs remain switched on a longer time than the duration of the ordinary flash, and a larger spot will be marked on the diagram. Once a month a man supervises the apparatus, and winds up the spring motor. He also reads the pore pressure value indicated by the Bourdon gauge. At the same time he checks the bulbs and the accumulators. Afterwards his readings can easily be correlated with known points on the records. Six months' experience with two recorders in the field has shown that they work satisfactorily.

§ 4 g. Experience with SGI System

Our practical experience with the SGI system mostly concerns the 6 cm filter pipe used together with the oil-filled pick-up. This combination is normally sufficient for Swedish clays.

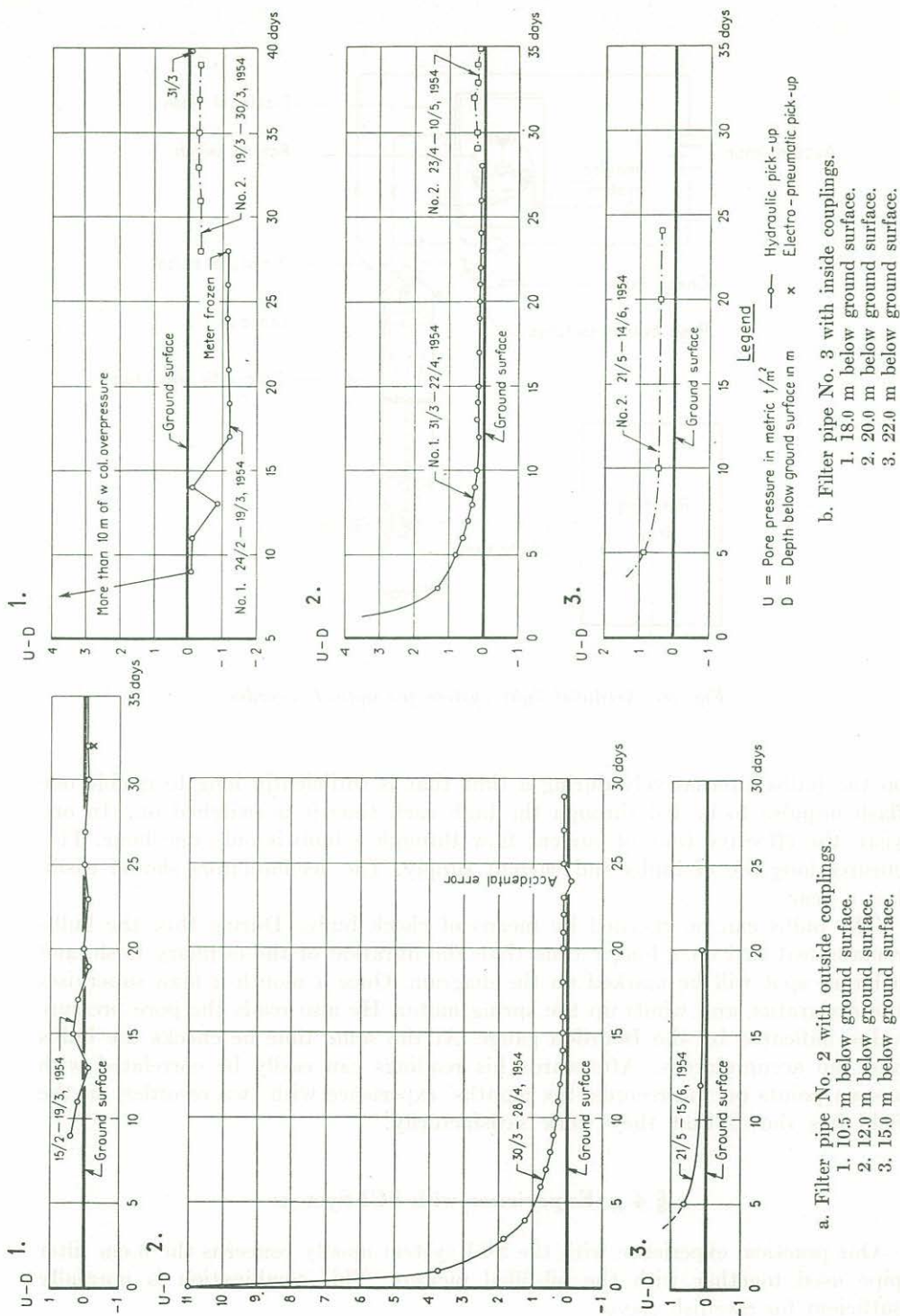
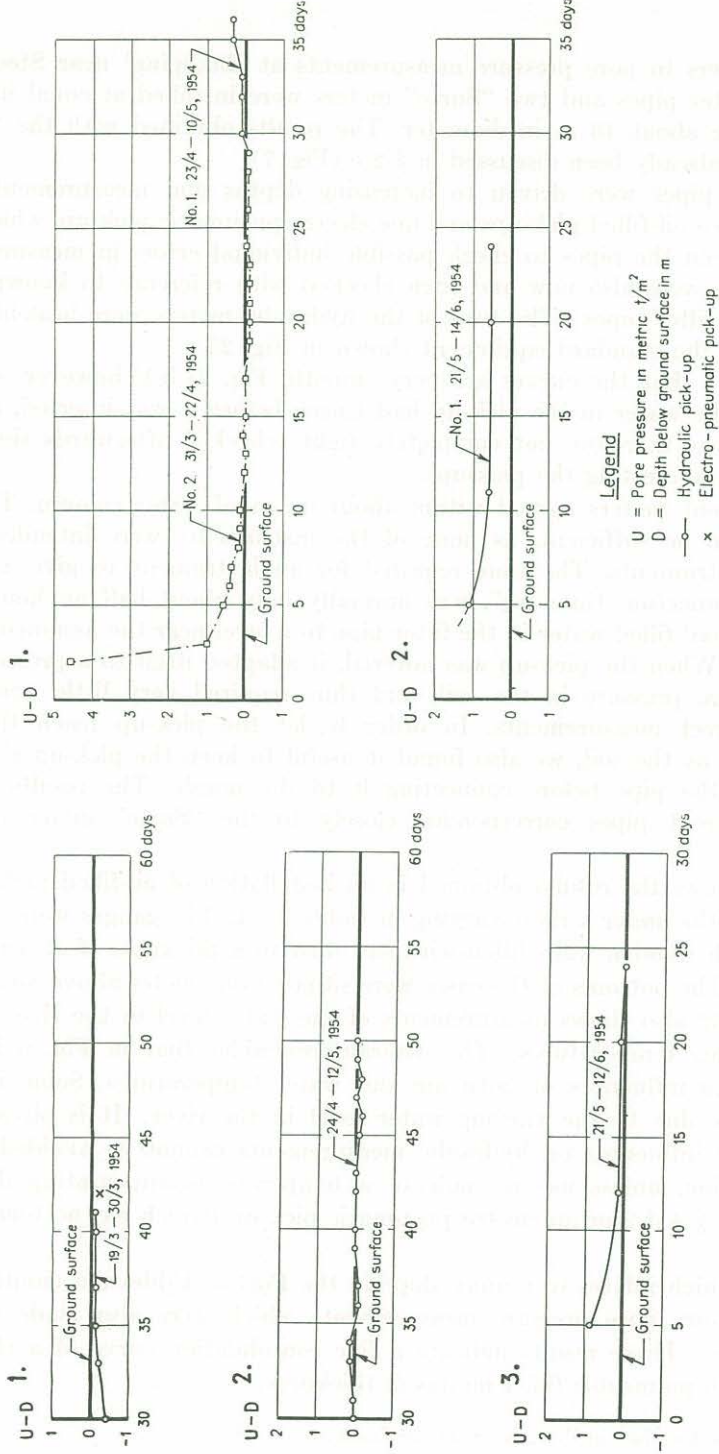

Fig. 31 a-b. Pore pressure measurements in clay at Enköping.



c. Filter pipe No. 5 with outside couplings.

1. 10.5 m below ground surface.
2. 12.0 m below ground surface.
3. 15.0 m below ground surface.

d. Filter pipe No. 6 with inside couplings.

1. 20.0 m below ground surface.
2. 22.0 m below ground surface.

Fig. 31 c—d. Pore pressure measurements in clay at Enköping.

Fig. 31 refers to pore pressure measurements at Enköping¹ near Stockholm. Four SGI filter pipes and two "Surte" meters were installed at equal intervals along a circle about 13 m in diameter. The results obtained with the "Surte" meters have already been discussed in § 2 c (Fig. 7).

The filter pipes were driven to increasing depths and measurements were made with two oil-filled pick-ups and one electro pneumatic pick-up, which were shifted between the pipes to check possible individual errors in measurements. The pick-ups were also now and then checked with reference to known water levels in the filter pipes. The tops of the hydraulic meters were heat-insulated by means of the standard equipment shown in Fig. 23.

We observe that the curves are very smooth. Fig. 31 b 1, however, shows a case where the water in the pick-up had frozen before it was inserted, and the connection was therefore not completely tight (checked afterwards simply by lifting and reconnecting the pick-up).

The different meters agreed within about 0.1 m of water column. This was considered to be sufficient, as none of the instruments were intended to be precision instruments. The time required for an instrument to give a correct reading, "connection time lag", was normally only about half an hour or so, because we had filled water in the filter pipe to a level near the assumed ground water level. When the pick-up was lowered, it adapted itself to a pressure very near the pore pressure in the soil, and thus required very little pore water to give correct measurements. In order to let the pick-up reach the same temperature as the soil, we also found it useful to keep the pick-up about ten minutes in the pipe before connecting it to the nozzle. The results relating to the different pipes corresponded closely to the "Surte" meter measurements.

Fig. 32 shows the results obtained in an installation of oil-filled meters sunk to great depths under a river varying in water level. The gauges were mounted in cases with wooden walls filled with saw-dust to a thickness of at least 0.2 m all around. The bottoms of the cases were situated one meter above mean water level. Fig. 32 also shows measurements of the water level in the river and the water and air temperatures. The diagram resembles that in Fig. 6 in shape but indicates influences of both air and water temperatures. Some influence may also be due to the varying water level in the river. It is obvious that temperature influences on hydraulic measurements cannot be avoided in such an installation, unless use is made of a temperature-compensating device as discussed in § 4 d 2 or an electro pneumatic pick-up (which has no temperature sensitivity).

Fig. 33 which relates to a quay slope in the Port of Uddevalla (southwestern Sweden) shows pore pressure measurements which were also made with oil-filled meters. These results indicate a fine consolidation curve of a clay layer covered with permeable fill, 4 metres in thickness.

¹ The site is described in Proc. No. 8 of the Institute.

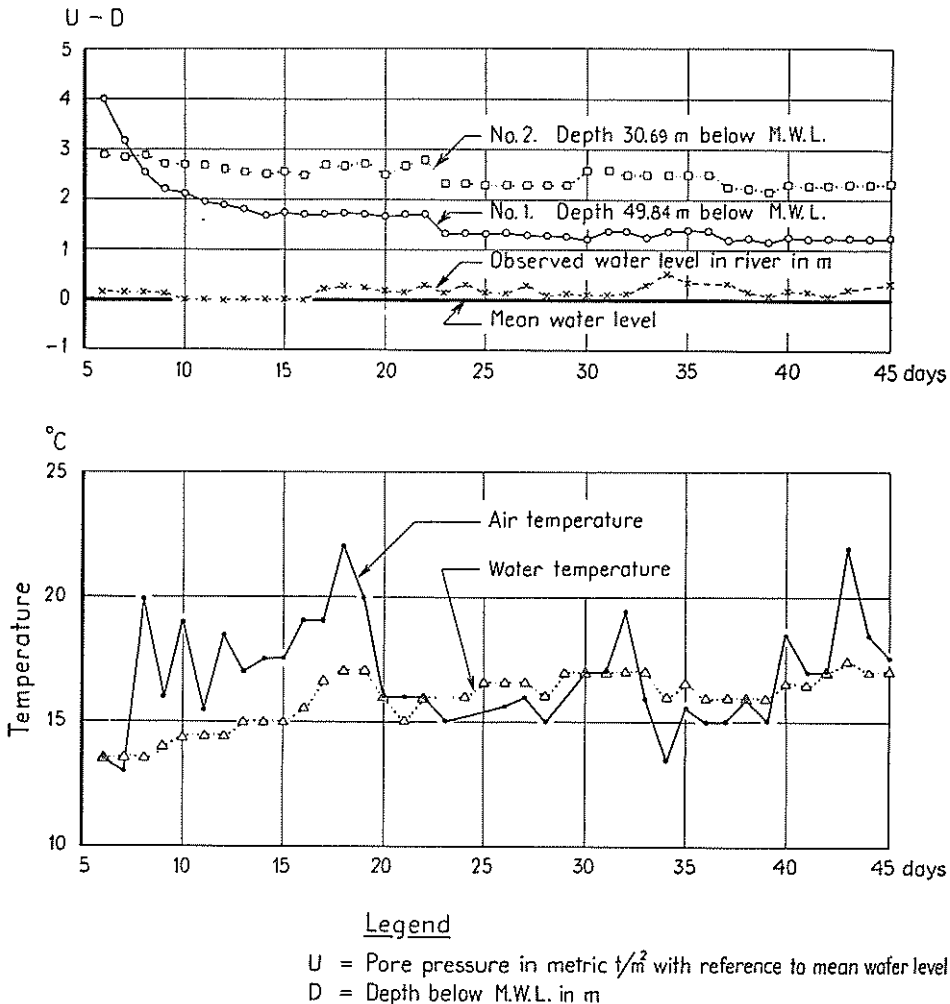

Fig. 32. Pore pressure measurements with hydraulic pick-up below the bottom of Göta River for a planned tunnel and comparative measurements of air and water temperature (June 29 to August 10, 1954).

In the cases represented in Figs. 31—33 the installation time lags were 8 to 12 days. Time lags half these values can be obtained with our latest filter pipe as already stated in § 4 c 1 (Fig. 18).

Our latest electro pneumatic pick-up has been tested for about a year, and seems to be reliable.

In one case we had to measure pore pressure in a soil containing much gases. Immediately after installation of the filter pipes many gas bubbles escaped through the water filled open pipes. When gas ceased to escape we connected meters and were able to measure without trouble.

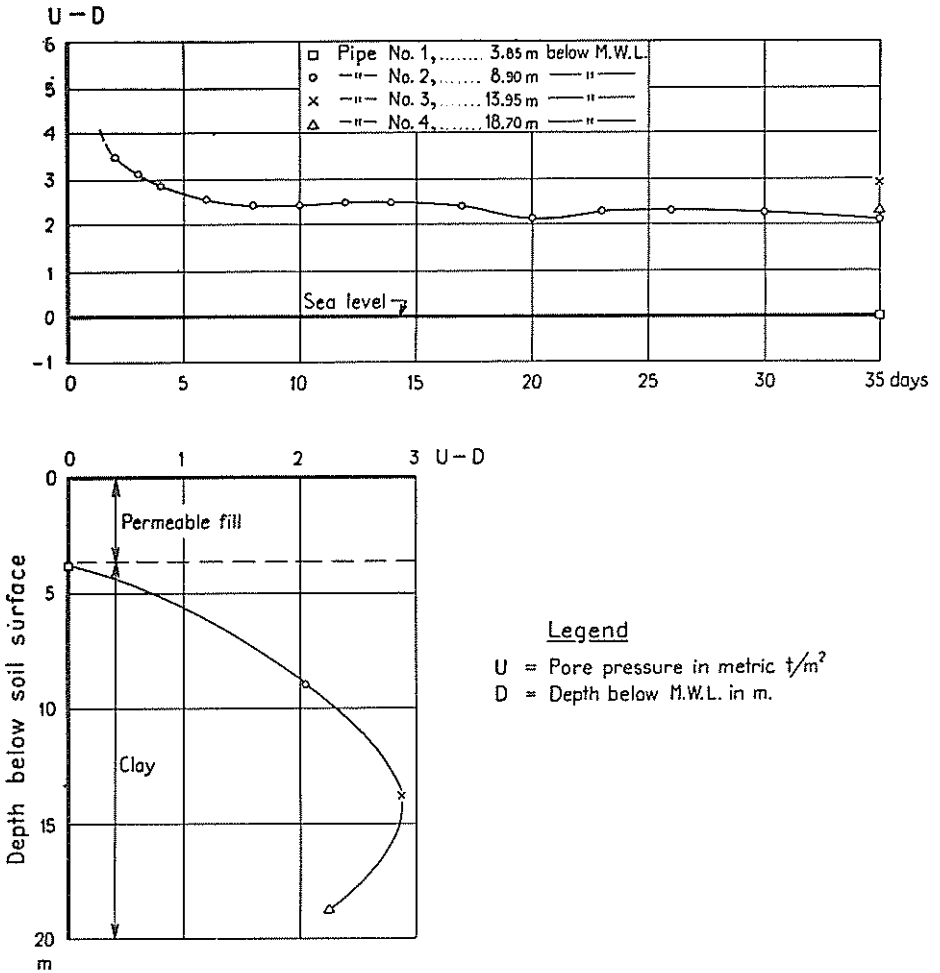

Fig. 33. Pore pressure measurements in a quay slope at Uddevalla (November 9 to December 14, 1955).

§ 5. Precision Pick-Up

The precision of the electro pneumatic pick-up can be considerably improved if we permit slightly greater measurement time lags. With a few alterations of the pick-up as described in § 4 d, this is possible.

The principle is shown in Fig. 34. Here the lower bellows is subjected only to the difference between the pore pressure on the inside and a certain static pressure on the outside, and not to the whole pore pressure, as described in § 4 d. The static pressure is produced by filling water to a desired level in the filter

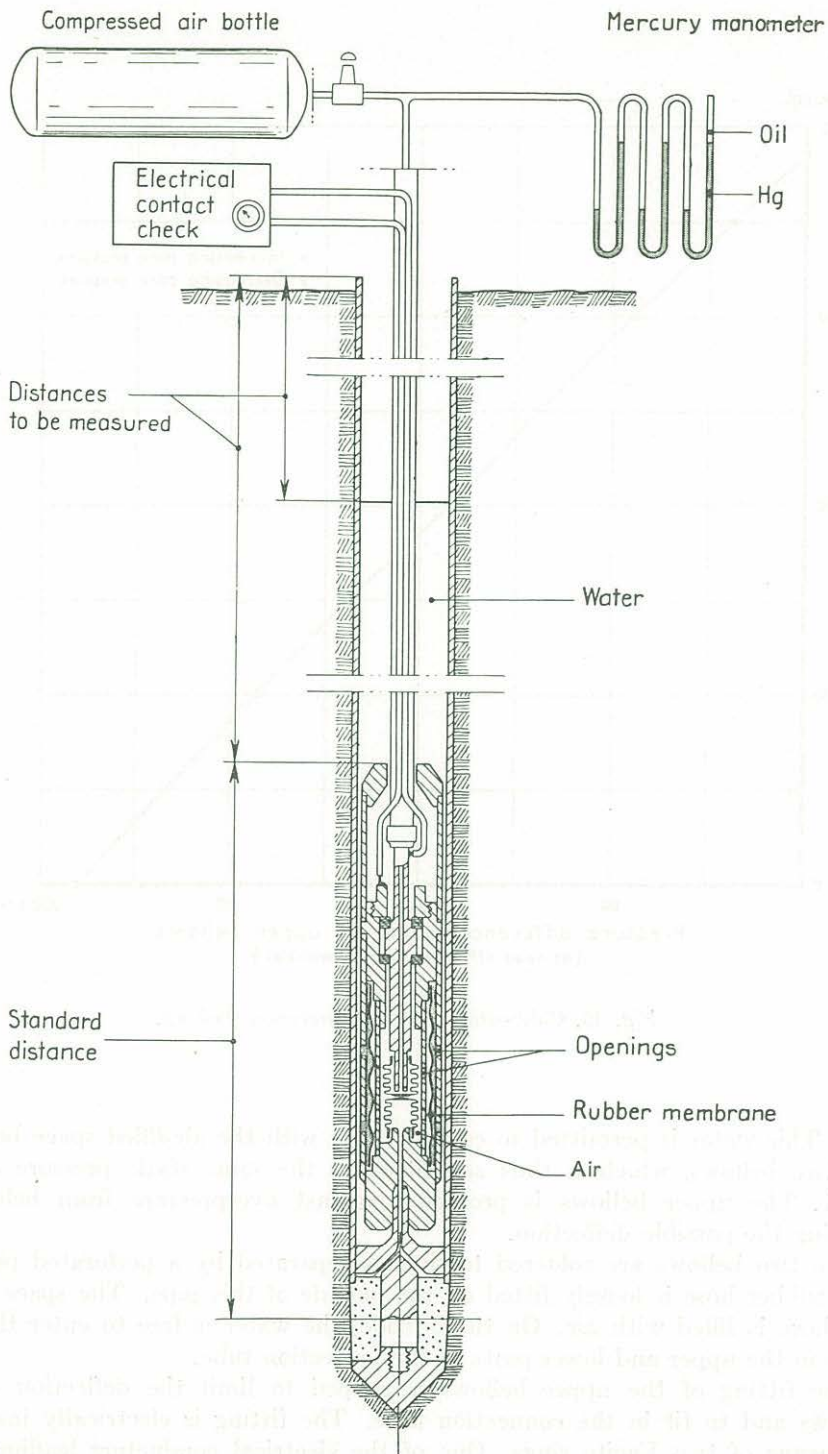

Fig. 34. Principle of precision electro pneumatic meter.

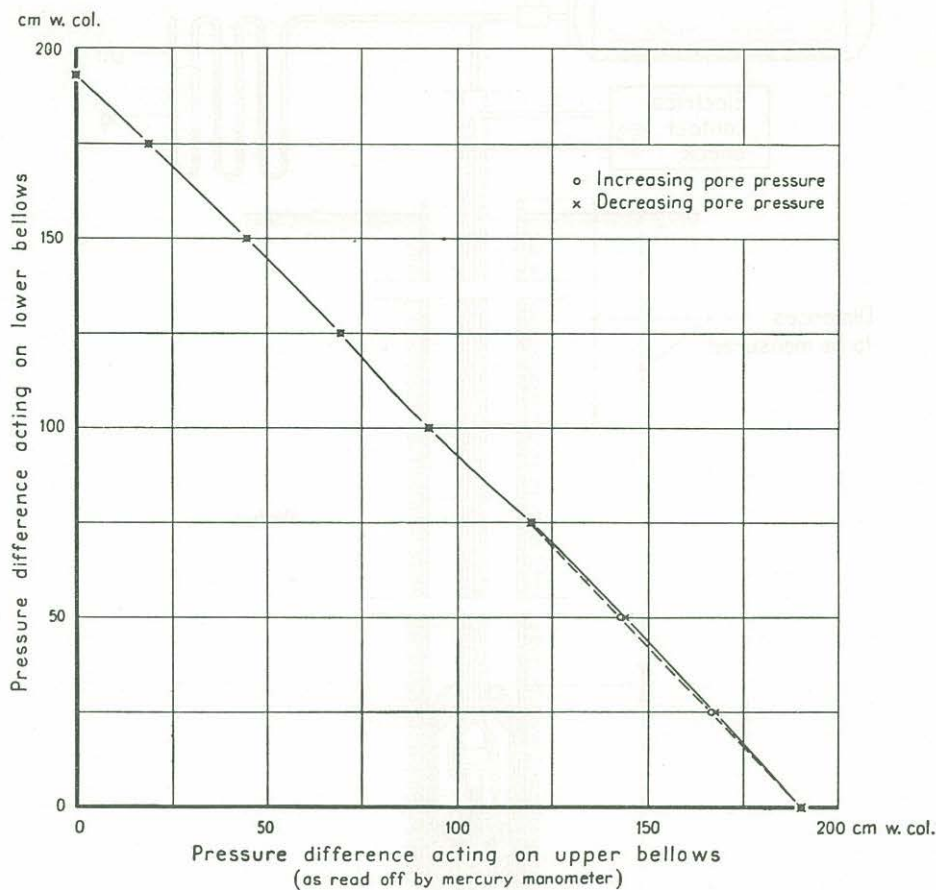

Fig. 35. Calibration curve of precision pick-up.

pipe. This water is permitted to communicate with the air-filled space between the two bellows, which is thus submitted to the same static pressure as the water. The upper bellows is protected against overpressure from below by limiting the possible deflection.

The two bellows are soldered to fittings separated by a perforated pipe. A thin rubber hose is loosely fitted on the outside of this pipe. The space inside this hose is filled with air. On the outside, the water is free to enter through holes in the upper and lower parts of the protection tube.

The fitting of the upper bellows is shaped to limit the deflection of the bellows and to fit in the connection hose. The fitting is electrically insulated by means of two Lucite rings. One of the electrical conductors leading from the contact-checking device is soldered to the fitting for the upper bellows,

and the other to the extension of the perforated pipe, which is electrically connected to the lower bellows.

The contact-checking device is exactly the same as that described in § 3 and § 4 c.

The bellows undergo a deflection of 0.32 mm in a pressure range of 2 m of water column. As the accuracy of the contacts is about 0.001 mm (§ 3 b), the sensitivity is about 6 mm of water column. The volume factor is about $10 \cdot 10^{-4}$ cm⁵/g, that is, of the same order, although a little higher, than for the instruments described in § 4.

We have successfully used a multiple mercury manometer for air pressure measurements. It has a range of 40 m of water column. Its accuracy is 1 cm of water column. In most cases it is sufficient to have a range of 10 m of water column, which corresponds to only one U-bend. The accuracy of the manometer is then higher than ± 5 mm of water column. Fig. 35 shows a calibration curve of the precision pick-up.

The accuracy in measurements is also dependent on the determination of the water level in the filter pipe and on the depth of the filter below ground level. Both can be determined by means of a single sounding operation inside the filter pipe, with an accuracy of a few millimetres.

Another advantage of this type of meter is its independence of the temperature.

The meter has only been ready a few months and our experience with it is therefore rather limited.

§ 6. Conclusions

From the above we can draw the following general conclusions.

Before starting pore pressure measurements it is recommendable to estimate the smallest accuracy and sensitivity in measurements that will be sufficient for the problem under consideration. Further, it is advisable to estimate the greatest probable change in pore pressure with the time and the permeability of the soil. These data will permit the selection of a suitable measuring instrument having the appropriate accuracy, sensitivity, "volume factor", pipe diameter, and "equivalent filter diameter". The cross-sectional area of the pipe is a measure of the installation time lag. Eqs. (10 a), (11 a), and (11 b) in § 1 b 2 can be used to calculate the measurement time lags, which are difficult to determine practically.

It is always desirable to use quick-response measuring systems, since errors due to great time lags are least probable in these systems. If we use such systems, then no selection is normally necessary. In clays this calls for closed measuring systems rather than for ordinary open pipes, because—if the filters are greater than a certain definite size—it is easier to decrease the measurement time lags by reducing the volume factor of the instrument than by increasing the filter area.

The simplest closed measuring system is the liquid-filled system with a Bourdon gauge. It requires no manipulation for reading, and therefore permits persons living near the site to take readings. By using oil instead of water in the system, the risk for gas bubbles is practically eliminated. Closed liquid-filled systems have the drawback of being considerably temperature-sensitive. However, this can be counteracted by using insulated boxes in close contact with the soil, or by using temperature-compensating devices.

For cases where the pore pressure is low in relation to the depth, an electro pneumatic measuring system can be used. The type designed by the Institute has the advantage of being unaffected by temperature. It is more intricate and more expensive than the liquid-filled system, and requires certain manipulations in measurements, but they do not generally affect the pore pressure in the soil.

The SGI system, with an in-situ connection, permits checking of the measurements, and prevents the meters from being damaged during installation. It also enables precision measurements by exchanging a wide-range instrument for a narrow-range pressure-compensated instrument.

For evaluation of measurements (transforming u_i to u_s , § 1 b 2), the instrument data and the soil permeability must be numerically known. Recording instruments are considered to be especially useful for evaluations.

Quick-acting instruments, and sometimes recording instruments, are economical since they save time and reduce the number of manual readings required to give reliable values.

The instruments above should not be regarded as a final solution for all kinds of pore pressure measurements. They contain, however, many considerations which contribute to a better understanding of such measurements.

§ 7. Summary

Measurement of pore water pressure in connection with field investigations is first treated in principle. It is shown that the accuracy and sensitivity in measurements, together with the "volume factor" of the instrument and the "equivalent filter diameter", determine the possibility of measuring variable pressures, and govern the time lags.

The development of pore water pressure meters at the Institute is described. This development resulted in a system of interchangeable parts (long filter, short filter, oil-filled pick-up, electro pneumatic pick-up, recording instruments, and a precision instrument). Disturbances due to temperature changes and gas bubbles were eliminated. Practical experiences are discussed.

LIST OF PUBLICATIONS
FROM THE ROYAL SWEDISH GEOTECHNICAL
INSTITUTE

Proceedings

- No. 1. Soil Sampler with Metal Foils. Device for Taking Undisturbed Samples of Very Great Length. *W. Kjellman, T. Kallstenius, and O. Wager* 1950
2. The Vane Borer. An Apparatus for Determining the Shear Strength of Clay Soils Directly in the Ground. *Lyman Cadling and Sten Odenstad* 1950
3. Device and Procedure for Loading Tests on Piles. *W. Kjellman and Y. Liljedahl* 1951
4. The Landslide at Sköttorp on the Lidan River, February 2, 1946. *Sten Odenstad* 1951
5. The Landslide at Surte on the Göta River, September 29, 1950. *Bernt Jakobson* 1952
6. A New Geotechnical Classification System. *W. Kjellman, L. Cadling, and N. Flodin* 1953
7. Some Side-Intake Soil Samplers for Sand and Gravel. *Torsten Kallstenius* 1953
8. Influence of Sampler Type and Testing Method on Shear Strength of Clay Samples. *Bernt Jakobson* 1954
9. Some Relations between Stress and Strain in Coarse-Grained Cohesionless Materials. *W. Kjellman and B. Jakobson* 1955
10. Accurate Measurement of Settlements. *W. Kjellman, T. Kallstenius, and Y. Liljedahl* 1955
11. Influence of Organic Matter on Differential Thermal Analysis of Clays. *Lennart Silfverberg* 1955
12. Investigations of Soil Pressure Measuring by means of Cells. *Torsten Kallstenius and Werner Bergau* 1956
13. Pore Water Pressure Measurement in Field Investigations. *Torsten Kallstenius and Alf Wallgren* 1956

Meddelanden

- No. 1. Kortfattat kompendium i geoteknik 1946 1946
2. Redogörelse för Statens geotekniska instituts verksamhet under åren 1944—1948 1949
3. »Bra borrar — bättre byggt». Meddelande utgivet till institutets deltagande i utställningen »Bygg bättre», Nordisk Byggnadsdag V 1950